

Welded Fittings

Catalog 4280
Revised, February 2003



Welded Fittings

Introduction

In the chemical industry, process pressures are climbing higher and higher. The utility field, with its high steam pressures and hydraulic and pneumatic shutdown systems, demands the utmost in reliability. Nuclear power plants with their "hot" materials also have massive reliability problems. Such problem areas have given rise to the increased use of the permanent-weld-type tube fittings which provide a sturdy, tight integral line system that remains unaffected by shock, vibration or thermal distortion. The Parker Weld-lok® line of permanent socket weld tube fittings meets the most exacting requirements of any system.

Heat Code Traceability

Parker Hannifin's Instrumentation Connectors Division offers Heat Code Traceability (HCT) on CPI™, A-LOK®, Instrumentation Pipe, Automatic Butt weld, and Weld-lok®.

HCT refers to the fact that a specific part can be traced back to the original mill heat of metal from which it was made. Beginning with the original melt, a package of documents is created which completely describes the metal in physical and chemical terms. The end result is that a number, which is permanently stamped to the part, refers back to the document package.

The HCT number is stamped on the material (bar stock or forging) prior to manufacturing. The concept is useful because it provides a method for complete material accountability for the manufacturer and end customer.

HCT offers these advantages:

- Raw materials for manufacture must meet code requirements. This can be verified through documentation so that the customer is certain that what is ordered is received.
- HCT provides a record of chemical analysis with the raw material. Thus, in areas requiring welding, the correct welding technique is applied.
- HCT relieves the user of Parker instrumentation tube fittings of any doubts. It acts as an assurance for today and for tomorrow.

The material used in Parker Hannifin instrumentation fitting components is 316 or 316L (welded products) stainless steel as specified and referenced in Section III of the ASME Boiler and Pressure Vessel code.

The American Society of Mechanical Engineers (ASME) Boiler and Vessel Code, Section III, latest issue, entitled Rules for Construction of Nuclear Power Plant Components, is the principal document covering this type of fitting in the nuclear field. ANSI Standard B.31.1, Power Piping, and ANSI Standard B.31.7, Nuclear Power Piping, are also important documents in the field.

In addition to the documentation of chemical and physical properties, great care is taken throughout the manufacture of Parker's tube fittings to ensure that potential stress corrosion will not be a problem in normal usage of the parts. Manufacturing processes avoid exposure of the parts to mercury or halogens, and control of thermal treatment avoids the condition known as continuous grain boundary carbide precipitation. (pg. 12)

For additional information please contact your local authorized Parker Instrumentation distributor or call Parker Instrumentation Connectors Division and ask for Bulletin 4230-B15.



WARNING

FAILURE, IMPROPER SELECTION OR IMPROPER USE OF THE PRODUCTS AND/OR SYSTEMS DESCRIBED HEREIN OR RELATED ITEMS CAN CAUSE DEATH, PERSONAL INJURY AND PROPERTY DAMAGE.

This document and other information from Parker Hannifin Corporation, its subsidiaries and authorized distributors provide product and/or system options for further investigation by users having technical expertise. It is important that you analyze all aspects of your application and review the information concerning the product or system in the current product catalog. Due to the variety of operating conditions and applications for these products or systems, the user, through its own analysis and testing, is solely responsible for making the final selection of the products and systems and assuring that all performance, safety and warning requirements of the application are met.

The products described herein, including without limitation, product features, specifications, designs, availability and pricing, are subject to change by Parker Hannifin Corporation and its subsidiaries at any time without notice.

Offer of Sale

The items described in this document are hereby offered for sale by Parker Hannifin Corporation, its subsidiaries or its authorized distributors. This offer and its acceptance are governed by the provisions stated in the "Offer of Sale".

Visual Index

Automatic Butt weld Fittings

Automatic Butt weld Union
YHY
page 7



Automatic Butt weld Union Tee
YJY
page 7

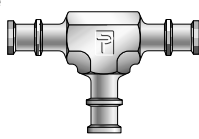

Automatic Butt weld Manifold Branch Tee
YJT3
page 7



Automatic Butt weld Manifold Run Tee
YJT3Y
page 8



Automatic Tube Butt weld Manifold Tee
T3JT3
page 8



Automatic Butt weld Union Elbow
YEY
page 9



Automatic Tube Butt weld Manifold Elbow
T3ET3
page 9



Automatic Butt weld Cross
YKY
page 10

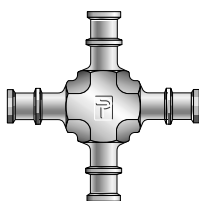

Automatic Butt weld to CPI™ Tube Union
YHBZ
page 10



Automatic Butt weld to A-LOK® Tube Union
YHLZ
page 10



Automatic Butt weld Adapter to Compression Port Connector
ZPY & BY
page 11

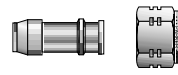

Automatic Butt weld Plug
PNY
page 11



Weld-lok® Socket Weld Tube Fittings

Union
HW
page 14



Tube Reducer
TRW
page 14



Elbow
EW
page 14



45° Elbow
NW
page 15



Tee
JW
page 15



Cross
KW
page 15



Male Elbow
CW
page 16



Male Connector
FW
page 16



Female Connector
GW
page 16



Female Elbow
DW
page 17



Male Run Tee
RW
page 17



Male Branch Tee
SW
page 17



Adapter
AW
Page 18



Adapter
AW2
page 19



Weld-lok® To Compression

Socket Weld Connector
ZHBW
page 21



Butt weld Connector
ZHBW2
page 22



Socket Weld Elbow
ZEBW
page 23



Butt weld Elbow
ZEBW2
page 23



Automatic Buttweld General Information

Automatic Buttweld Purpose

Parker Buttweld fittings are designed for applications requiring the reliability of a welded tubing system. They were developed specifically for installation using automatic, orbital TIG (Tungsten/Inert Gas) welding equipment. These fittings offer the easiest, fastest and most reliable way to fabricate welded systems.

Automatic Buttweld fittings are available in 316, and 316L stainless steel in straight unions, tees, 90° elbows, and crosses. Automatic Buttweld ends are also available with male pipe and compression tube connections.

Pressure

Pressure ratings will be governed by the tubing wall thickness selected for a particular application.

Working pressures are rated at room temperature based on a 4 to 1 design factor. Pressure ratings are calculated in accordance with ANSI Power Piping Code B31.1.

Automatic Buttweld Principles of Operation

In an orbital welder, the electrode is contained and shielded within the head (see Figure 3). The head itself does not rotate; rather, the electrode rotates 360° within the head.

An orbital-type welder utilizes high-frequency current pulses, producing low-frequency arc pulses. These yield considerable arc penetration into the metal at low current values. As a result, arc-pressure variations are kept low and the resulting agitation of the weld puddle eliminates porosity and refines the grain structure at the weld area.

To operate a TIG welding machine

1. Place the Automatic Buttweld fitting into the weld head, placing the locator rib in the corresponding locator groove.
2. Bottom the tubing (square cut, deburred) in the fitting end collar and close the second collet, which locks the tubing to the weld head. Engage the second collet.
3. Close the weld head. Press the "Start" button.

Note: Depending on the size and wall-thickness of the tubing, the welding machine parameters can be programmed to make one or more 360° passes. Once programmed, the machine will repeat the operation precisely, within very close tolerances and in areas too tight for manual welding.

Backing Gas

Backing gas is an inert gas used to flood the interior of the fittings and tube system during welding. By reducing the interior oxygen level to as low as practicable, it also serves to control the combustion of contaminants that could affect weld quality.

When a backing gas is not used and nearly 100% weld penetration is achieved, blisters will tend to form on the internal tube wall. This will result in scale which may later break loose.

In most cases the backing gas will be argon or helium connected to the system through a control regulator. Flow rates,

Automatic Centering of Electrode

Each Parker Automatic Buttweld fitting has an external locator rib (patented) situated a fixed distance from the end welding collar (see Figure 1). When the welder-head clamping collet is applied, the rib fits snugly within a corresponding annular groove in the collet.

As the electrode orbits, the collet follows the rib, maintaining precise positioning of the electrode, over the end collar (see Figure 2). Thus, electrode and welding positioning are always accurately aligned.

End Weld Collar

On the O.D. of each Automatic Buttweld fitting end, there is an end collar. During welding, the electrode tip is positioned directly over this end collar. As the electrode orbits, a uniform bead on the butt-seam is achieved.

Piloted Mating of Tube to Fitting

The end collar of the Automatic Buttweld fitting is counter bored. This serves as a pilot for the tube end, guiding it accurately into the fitting end.

This feature provides for accurate alignment and consistent welds every time.

Compensation for Tube-Thickness Variations

The outside diameter of the end collar is designed to compensate for normal variations in the nominal O.D. of instrumentation tubing.

In addition, each fitting is machined for the specific wall thickness being specified.

These two features allow for the fitting bore and tube I.D. to be carefully matched. Thus, an ABW connection will allow for full flow, with no protrusions extending into the flow path. This will reduce a major cause of turbulence.

while small, should be high enough to purge the system. Welds should be made in downstream sequence from the gas connection.

Note that the entire system should be purged to insure that there are no openings that will allow air to be drawn into the system.

The use of backing gas, while often not mandatory, will give a better weld joint. This is because the welds are made and cooled under a shielded atmosphere, thus eliminating internal scaling or blistering.

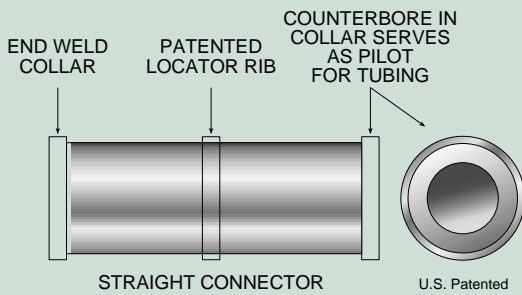

Figure 1 – The Automatic Buttweld fitting has a locator rib positioned a fixed distance from the end weld collar.

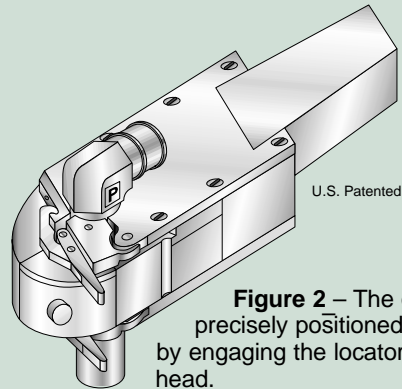

Figure 2 – The orbiting electrode is precisely positioned over the end collar by engaging the locator rib within the weld head.

Note: The weld head shown is for illustration only.

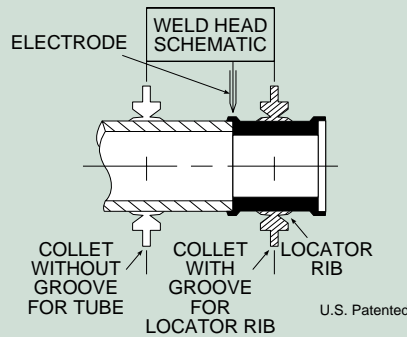

Figure 3 – The orbital welder electrode is shielded within the stationary head and rotates 360° to produce uniform, accurate welds.

Materials

Automatic Buttweld Tube Fittings are available in stainless steel (Type 316 and 316L - AOD/VAR and 316L VIM/VAR). Straight fittings are machined from cold finished bar stock and shaped bodies are machined from close grain forgings. The raw materials used for fittings fully conform to the chemical and mechanical requirements of one or more of the specifications listed in the table on page 6. For nuclear and other critical applications, Automatic Buttweld fittings are available with documented heat code traceability. (See page 2)

How to Order Automatic Butt weld

Nomenclature

Parker Automatic Butt weld Tube Fittings part numbers are constructed from symbols that identify the size and configuration of the fittings and material used.

How To Order

Parker Butt weld components are ordered by part number as listed in this catalog.

Example: If your system requires an elbow fitting going from 1/4" tubing to 1/4" tubing, .035 wall thickness, you would order the following part:

4-4 YEY-SS .035 (Automatic Butt weld)

Fitting Size – The first two numbers denote the fitting size which matches the tubing O.D.

Machining Type – First end ABW only (Y).

Fitting Type – Straight (H), Union tee (J), Union elbow (E).

Machining Type – Second end, ABW (Y), Male pipe (F), CPI™/A-LOK® end assembled (BZ/LZ).

Wall Thickness – Fittings must be specified to match the corresponding tube wall thickness. Standard wall thicknesses:
 Size 4 and 6 – .035 wall thickness
 Size 8 – .049 wall thickness
 Other wall thicknesses available upon request.

Material – Stainless Steel - SS (316L)
 AOD/VAR - SSR (316R)
 VIM/VAR - SSV (316V)

Size: Tube and pipe thread sizes are designated by the number of sixteenths of an inch (1/4" tube = 4/16" = size 4), (3/8" tube = 6/16" = size 6), and (1/2" tube = 8/16" = size 8).

Special fittings: If a special fitting configuration is required, it is suggested that a sketch or drawing be submitted for review.

Availability: Only items listed in current price list are carried in stock. Customer Specials may be quoted through Parker ICD Division Customer Service.

TYPICAL RAW MATERIAL SPECIFICATIONS			
FITTING MATERIAL	BAR STOCK	FORGINGS	RECOMMENDED TUBING SPECIFICATIONS
Stainless Steel 316L	ASTM A-276 TYPE 316LSS ASME SA-479 TYPE 316L-SS	ASME SA-182 GRADE 316L	ASME SA-213 ASTM A-213 ASTM A-249 ASTM A-269 MIL T-8504 MIL T-8506
Stainless Steel 316L (AOD/VAR)			
Stainless Steel 316L (VIM/VAR)			

Automatic Butt weld Fittings

Automatic Butt weld Union YHY

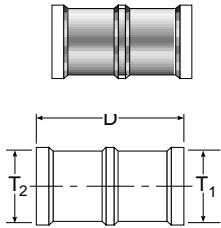

PART NO.	INCHES			*AUTO-BUTTWELD WALL SIZE
	D	T ₁	T ₂	
4-4 YHY	0.77	1/4	1/4	.035-.035
6-4 YHY	1.34	3/8	1/4	.035-.035
6-6 YHY	0.77	3/8	3/8	.035-.035
8-4 YHY	1.48	1/2	1/4	.049-.035
8-6 YHY	1.48	1/2	3/8	.049-.035
8-8 YHY	0.77	1/2	1/2	.049-.049
12-12 YHY	1.07	3/4	3/4	.065-.065
16-16 YHY	1.07	1	1	.095-.095

*Other fittings and wall sizes available upon request

Automatic Butt weld Union Tee YJY

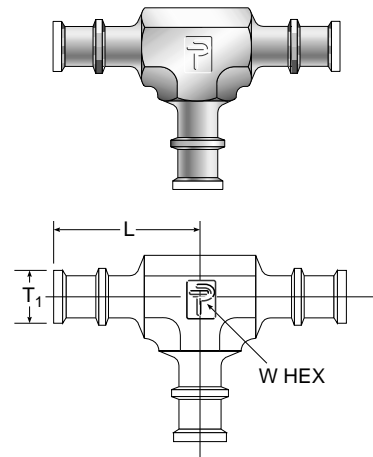

PART NO.	INCHES			W HEX
	L	T ₁	*AUTO-BUTTWELD WALL SIZE	
4-4-4 YJY	1.06	1/4	.035	7/16
6-6-6 YJY	1.19	3/8	.035	9/16
8-8-8 YJY	1.44	1/2	.049	3/4
12-12-12 YJY	1.64	3/4	.065	1-1/16
16-16-16 YJY	1.81	1	.095	1-5/16

*Other fittings and wall sizes available upon request

Automatic Butt weld Manifold Branch Tee YJT3

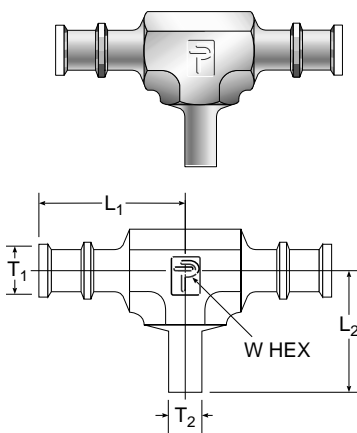

PART NO.	INCHES				*AUTO-BUTTWELD WALL SIZE	W HEX
	L ₁	L ₂	T ₁	T ₂		
4-4-4 YJT3	1.06	1.03	1/4	1/4	.035	7/16
6-6-4 YJT3	1.19	1.15	3/8	1/4	.035	9/16

*Other fittings and wall sizes available upon request

Dimensions for reference only, subject to change.

Automatic Butt weld Fittings

Automatic Butt weld Manifold Run Tee YJT3Y

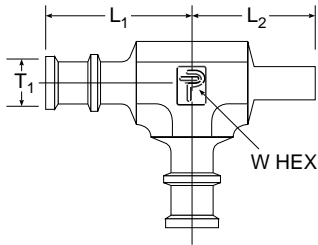
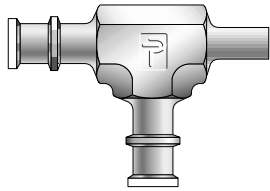

PART NO.	INCHES				
	L_1	L_2	T_1	*AUTO-BUTTWELD WALL SIZE	W HEX
4-4-4 YJT3Y	1.06	1.03	1/4	.035	7/16

*Other fittings and wall sizes available upon request

Automatic Tube Butt weld Manifold Tee T3JT3

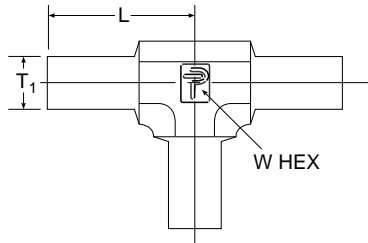
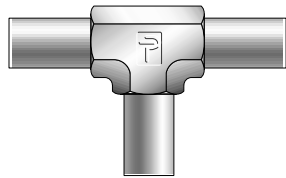

PART NO.	INCHES		
	L	T_1	W HEX
4-4-4 T3JT3	1.03	1/4	7/16

Dimensions for reference only, subject to change.

Automatic Butt weld Fittings

Automatic Butt weld Union Elbow YEY

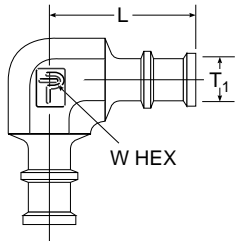
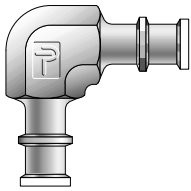

PART NO.	INCHES			
	L	T ₁	*AUTO-BUTTWELD WALL SIZE	W HEX
4-4 YEY	1.06	1/4	.035	7/16
6-6 YEY	1.19	3/8	.035	9/16
8-8 YEY	1.44	1/2	.049	3/4
12-12 YEY	1.64	3/4	.065	1-1/16
16-16 YEY	1.81	1	.095	1-5/16

*Other fittings and wall sizes available upon request

Automatic Tube Butt weld Manifold Elbow T3ET3

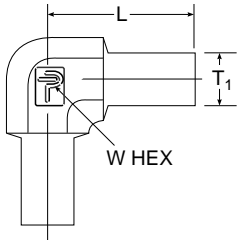
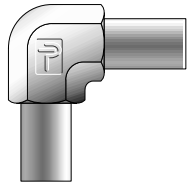

PART NO.	INCHES		
	L	T ₁	W HEX
4-4 T3ET3	1.03	1/4	7/16

Dimensions for reference only, subject to change.

Automatic Butt weld Fittings

Automatic Butt weld Cross YKY

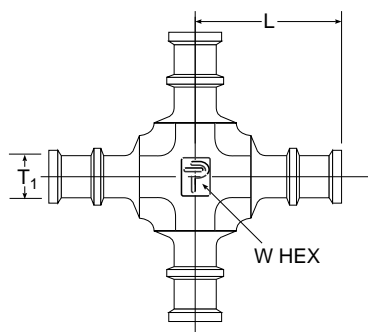
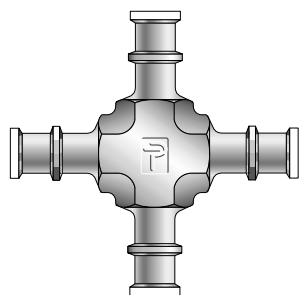

PART NO.	INCHES			
	L	T ₁	*AUTO-BUTT WELD WALL SIZE	W HEX
4 YKY	1.06	1/4	.035	7/16
6 YKY	1.19	3/8	.035	9/16
8 YKY	1.44	1/2	.049	3/4

*Other fittings and wall sizes available upon request

Automatic Butt weld to Tube Union

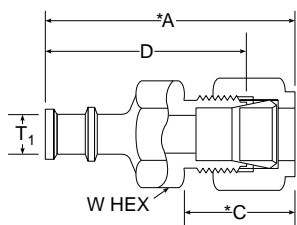
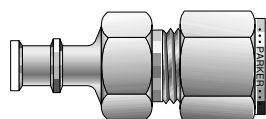

CPI™

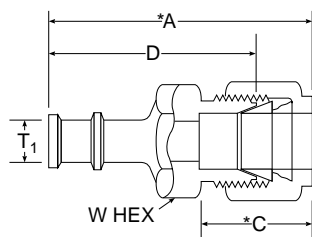
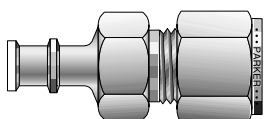

A-LOK®

PART NO. (CPI™)	INCHES					
	D	T ₁	*A	*C	**AUTO-BUTT WELD WALL SIZE	W HEX
4-4 YHBZ	1.42	1/4	1.71	.70	.035	1/2
6-6 YHBZ	1.51	3/8	1.80	.78	.035	5/8
8-8 YHBZ	1.71	1/2	2.11	.91	.049	13/16

Silver plated nut and single ferrule are provided as shown.

*Dimensions shown with nut finger tight

**Other fittings and wall sizes available upon request.

PART NO. (A-LOK®)	INCHES					
	D	T ₁	*A	*C	**AUTO-BUTT WELD WALL SIZE	W HEX
4-4 YHLZ	1.42	1/4	1.71	.70	.035	1/2
6-6 YHLZ	1.51	3/8	1.80	.76	.035	5/8
8-8 YHLZ	1.71	1/2	2.11	.87	.049	13/16

Silver plated nut and ferrules are provided as shown.

*Dimensions shown with nut finger tight

**Other fittings and wall sizes available upon request.

Dimensions for reference only, subject to change.

Automatic Butt weld Adapter to Compression Port Connector ZPY

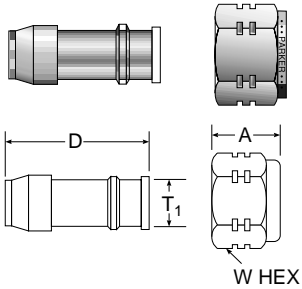

BODY PART NO.	INCHES		
	D	T ₁	*AUTO-BUTT WELD WALL SIZE
4-4 ZPY	1.12	1/4	.035
6-6 ZPY	1.09	3/8	.035
8-8 ZPY	1.52	1/2	.049
12-12 ZPY	1.50	3/4	.049
16-16 ZPY	1.71	1	.083

NUT PART NO.	INCHES	
	A	W HEX
4 BY	.50	9/16
6 BY	.56	11/16
8 BY	.69	7/8
12 BY	.69	1-1/8
16 BY	.81	1-1/2

*Other fittings and wall sizes available upon request

Automatic Butt weld Plug PNY

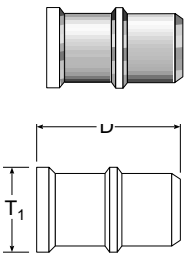

PART NO.	INCHES		
	D	T ₁	*AUTO-BUTT WELD WALL SIZE
4 PNY	0.72	1/4	.035
6 PNY	0.72	3/8	.035
8 PNY	0.72	1/2	.049
12 PNY	1.02	3/4	.065
16 PNY	1.02	1	.095

*Other fittings and wall sizes available upon request

Dimensions for reference only, subject to change.

Weld-lok® General Information

Weld-lok® Socket Weld Fittings

The weld used in joining a tube to a socket weld tube fitting is like any other type of “tee” weld. The root (i.e., the point of intersection of the outside of the tube and annular end area of the fitting) must be included in the weld zone.

Careful welding procedures are normally followed to assure that this root area is included in the weld. If penetration is not achieved, the joint will have two built-in stress risers which may greatly reduce the strength of the weld. Upon application of an extreme load, these stress risers could result in cracks which could propagate out through the weld or tube depending upon the direction of the greatest load.

Often to achieve full root penetration in TIG welding of stainless steels, a fusion pass will be made first, followed by a final pass utilizing a filler rod to achieve the desired fillet size.

Assembly

The codes applicable to the welding of socket weld fittings require that the tube be inserted into the socket until bottomed against the stop. The tube is then to be backed out approximately 1/16 of an inch and then welded.

If the tube is not backed out, but welded when against a flat bottom stop, the contraction of the weld fillet and fitting socket can combine to produce a static stress on the weld. During thermal transients, the fitting and the portion of the tube within the fitting may experience a differential rate of heating or cooling, again adding to the stress level in the weld.

Tacking

If the weld joint is to be “tacked” before welding, it is recommended that the “Tack” weld build-up be held to a minimum.

Excessive build-up on the “tack” may cause an interrupted final bead and a stress riser or lack of complete fusion.

Backing Gas

Backing gas is an inert (no active properties) gas used to flood the interior of the fittings and tube system during welding. It serves the same purpose internally as the shielding gas used in TIG or MIG welding. By reducing the interior oxygen level to as low as practicable, it also serves to control the combustion of contaminants that could affect weld quality.

When a backing gas is not used and nearly 100% weld penetration is achieved, blisters will tend to form on the internal tube wall. This will result in scale which may later break loose. Therefore, in 0.050 wall or thinner tube or where the wall thickness is such that the selected weld process may burn through, the use of a backing gas is required.

In most cases the backing gas will be argon or helium connected to the system through a control regulator. Flow rates, while small, should be high enough to purge the system. Welds should be made in downstream sequence from the gas connection.

Note that the entire system should be purged to insure that there are no openings that will allow air to be drawn into the system.

The use of backing gas, while often not mandatory, will give a better weld joint. This is because the effects of contaminate combustion by-products are eliminated and because the welds are made and cooled under a shielded atmosphere, thus eliminating internal scaling or blistering.

Welding Methods

Arc Polarity

When welding Weld-lok® fittings, best results will be obtained by the following arc polarities:

TIG – Direct Current, straight polarity
MIG – Direct Current, reverse polarity
STICK – Polarity dependent on rod used.

300 Series Stainless Steels

May be welded by the TIG, MIG, or stick arc-weld process.

TIG welding is recommended as being best for welding Weld-lok® systems because it allows better operator control of heat penetration and filler material deposition.

Stick arc welding is not recommended in many cases because of the likelihood of excessive burn-through and improper root penetration. In all cases where stick welding is used, it is recommended that backing gas be used.

MIG welding gives the same characteristics as stick electrode welding with faster deposition of the filler material. As this process runs “hotter” than the stick process, the use of a backing gas is mandatory. It should be noted that in welding the relatively small fitting sizes found in the Weld-lok® line, filler deposition rate economies are not a factor and therefore the MIG method is not commonly applied.

C1018 Steel Fittings

May be welded by the TIG, MIG, stick and oxyacetylene methods. As scale formation remains a problem, the use of a backing gas is still recommended.

Carbide Precipitation

When unstabilized stainless steels are heated to 800°–1500°F during welding, the chromium in the steel combines with the carbon to form chrome carbides which tend to form along the grain boundaries of the metal (carbide precipitation). This lowers the dissolved chromium content in these areas and thus lowers their corrosion resistance, making them vulnerable to intergranular corrosion. Carbide precipitation is reduced by holding the carbon content of the material to a very low value. This limits the amount of carbon available to combine with the chromium. The “L” series (extra low carbon) stainless steels are often used for this purpose, but their use reduces system design stress by approximately 15%. Parker Weld-lok® fittings are made from a select 316 series with carbon content in the low range of 0.04 to 0.07 percent. This results in a welded fitting with good corrosion resistance and a high strength factor.

All Parker Weld-lok® fittings in stainless steel are supplied in the solution-treated condition, capable of passing ASTM-A-262 Tests for Detecting Susceptibility to Intergranular Corrosion.

How To Order

Parker Weld-lok® components are ordered by part number as listed in this catalog.

Example: If your system requires a 90° elbow fitting going from 1/4" tubing to 1/4" tubing, you would order the following part:

4-4 EW-SS

Fitting Size – The first two numbers denote the fitting size which matches the tubing O.D.

Material – Stainless Steel - SS (316L)

Welded Fitting Type – Straight (H), Union tee (J), Union elbow (E).

Machining Type – Weld-lok® (W)

Size: Tube and pipe thread sizes are designated by the number of sixteenths of an inch (1/4" tube = 4/16" = size 4), (3/8" tube = 6/16" = 6), and (1/2" tube = 8/16" = size 8).

Special fittings: If a special fitting configuration is required, it is suggested that a sketch or drawing be submitted for review.

Availability: Only items listed in current price list (4280) are carried in stock. Customer Specials may be quoted through the Parker ICD Quick Response Department.

TYPICAL RAW MATERIAL SPECIFICATIONS			
FITTING MATERIAL	BAR STOCK	FORGINGS	RECOMMENDED TUBING SPECIFICATIONS
Stainless Steel 316L	ASTM A-276 TYPE 316LSS ASME SA-479 TYPE 316L-SS	ASME SA-182 GRADE 316L	ASME SA-213 ASTM A-213 ASTM A-249 ASTM A-269 MIL T-8504 MIL T-8506
Stainless Steel 304	TBA	TBA	

Where To Order

Parker Weld-lok® components are ordered with the Instrumentation Connectors Division.
 P.O. Box 400004-1504
 Huntsville, AL 35815-1504
 Phone: 256-881-2040

Design Specifications

The Weld-lok® fitting has been designed and tested in accordance with ANSI B16.11, which covers "Forged Steel Fittings Socket Welded and Threaded." Our design parallels the Schedule 80, 3000-pound fitting pressure class, and is compatible with O.D. tube wall thickness meeting the related (3000-psi pipe class) pressure requirements. Strong, full section forgings are used for all "shape" fittings.

User Specification Requirements

The 316 stainless steel Weld-lok® fittings fully conforms to the applicable specifications covered in:

- ANSI B31.1 "Power Piping"
 - ANSI B31.7 "Nuclear Power Piping"
 - Section III, "Nuclear Power Plant Component," ASME Boiler and Pressure Vessel Code
- Customer Specials may be quoted through the Parker Quick Response Department.

Weld-lok® Socket Weld Tube Fittings

Union

HW • tube socket end – both ports

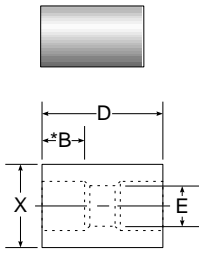

PART NO.	TUBE O.D.	TUBE O.D.	E SMALL BORE	*B	D	J	X DIA.	WORK. PRES.
2 HW	1/8	1/8	.09	.156	.69		.375	10,200
3 HW	3/16	3/16	.14	.203	.78		.438	9,600
4-3 HW	1/4	3/16	.14	.25-.20	.85	.44-.39	.50-.44	9,600
4 HW	1/4	1/4	.19	.250	.88		.500	9,600
5 HW	5/16	5/16	.25	.313	1.00		.594	9,900
6-4 HW	3/8	1/4	.19	.34-.25	1.00	.53-.44	.63-.50	8,100
6 HW	3/8	3/8	.31	.344	1.06		.625	8,100
8-4 HW	1/2	1/4	.19	.41-.25	1.11	.59-.44	.78-.50	7,300
8-6 HW	1/2	3/8	.31	.41-.34	1.17	.59-.53	.78-.63	7,300
8 HW	1/2	1/2	.44	.406	1.19		.781	7,300
10-6 HW	5/8	3/8	.31	.47-.34	1.28	.66-.53	.94-.63	6,600
10 HW	5/8	5/8	.50	.469	1.31		.938	6,600
12-4 HW	3/4	1/4	.19	.50-.25	1.30	.69-.44	1.09-.50	6,000
12-8 HW	3/4	1/2	.44	.50-.41	1.37	.69-.59	1.09-.78	6,000
12-10 HW	3/4	5/8	.50	.50-.47	1.39	.69-.66	1.09-.94	6,000
12 HW	3/4	3/4	.66	.500	1.38		1.094	6,000
14 HW	7/8	7/8	.78	.500	1.38		1.312	5,700
16-8 HW	1	1/2	.44	.56-.41	1.53	.75-.59	1.44-.78	4,900
16-12 HW	1	3/4	.66	.56-.50	1.54	.75-.69	1.44-1.09	4,900
16 HW	1	1	.91	.563	1.50		1.44	4,900
20-12 HW	1-1/4	3/4	.66	.63-.50	1.69	.81-.69	1.75-1.09	4,600
20-16 HW	1-1/4	1	.91	.63-.56	1.65	.81-.75	1.75-1.44	4,600
20 HW	1-1/4	1-1/4	1.06	.625	1.625		1.750	4,600
24-8 HW	1-1/2	1/2	.44	.67-.41	1.80	.86-.59	2.0-.78	3,700
24-16 HW	1-1/2	1	.91	.67-.56	1.77	.86-.75	2.0-1.44	3,700
24-20 HW	1-1/2	1-1/4	1.06	.67-.63	1.74	.86-.81	2.0-1.75	3,700
24 HW	1-1/2	1-1/2	1.31	.670	1.84		2.0	3,700
32-16 HW	2	1	.91	.78-.56	2.06	.97-.75	2.62-1.44	3,300
32 HW	2	2	1.81	.781	2.13		2.625	3,300

*Socket Depth

Tube Reducer

TRW • tube socket reducer

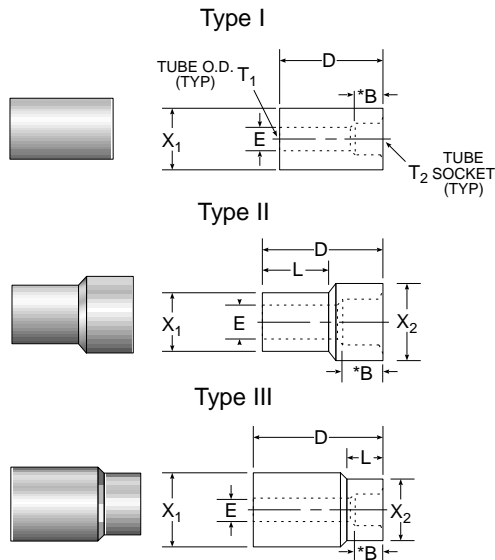

PART NO.	T ₁ SIZE	T ₂ TUBE SOCK.	TYPE	D	X ₁ DIA.	X ₂ DIA.	L	E SMALL BORE	*B	WORK. PRES.
6-4 TRW	3/8	1/4	II	.94	.375	.500	.47	.19	.250	9,600
8-4 TRW	1/2	1/4	I	.88	.500	.50	-	.19	.250	9,600
8-6 TRW	1/2	3/8	II	1.13	.500	.63	.56	.31	.344	7,800
10-4 TRW	5/8	1/4	III	1.22	.623	.50	.44	.19	.250	9,600
10-6 TRW	5/8	3/8	I	1.03	.623	.62	-	.31	.344	8,100
10-8 TRW	5/8	1/2	II	1.26	.623	.78	.63	.41	.406	6,100
12-4 TRW	3/4	1/4	III	1.32	.750	.50	.44	.19	.250	9,600
12-6 TRW	3/4	3/8	III	1.38	.750	.63	.53	.31	.344	8,100
12-8 TRW	3/4	1/2	II	1.29	.750	.78	.69	.44	.406	7,300
12-10 TRW	3/4	5/8	II	1.40	.750	.94	.69	.50	.469	6,600
16-4 TRW	1	1/4	III	1.44	1.000	.50	.44	.19	.250	9,600
16-6 TRW	1	3/8	III	1.50	1.000	.63	.53	.31	.344	8,100
16-8 TRW	1	1/2	III	1.51	1.000	.78	.59	.44	.406	7,300
16-10 TRW	1	5/8	III	1.52	1.000	.94	.66	.50	.469	6,600
16-12 TRW	1	3/4	II	1.47	1.000	1.09	.75	.66	.500	6,000
20-4 TRW	1-1/4	1/4	III	1.65	1.250	.50	.44	.19	.250	9,600
20-6 TRW	1-1/4	3/8	III	1.68	1.250	.63	.53	.31	.344	8,100
20-8 TRW	1-1/4	1/2	III	1.73	1.250	.78	.59	.44	.406	7,300
20-12 TRW	1-1/4	3/4	III	1.73	1.250	1.09	.69	.66	.500	6,000
20-16 TRW	1-1/4	1	II	1.68	1.250	1.44	.88	.91	.563	4,900
24-12 TRW	1-1/2	3/4	III	1.85	1.500	1.09	.69	.66	.500	6,000
24-16 TRW	1-1/2	1	III	1.81	1.50	1.34	.75	.91	.563	4,900
24-20 TRW	1-1/2	1-1/4	II	1.70	1.500	1.75	.81	1.06	.625	4,600

*Socket Depth

NOTE: Other drop sizes available upon request.
Dimensions for reference only, subject to change.

Weld-lok® Socket Weld Tube Fittings

Elbow

EW • tube socket end – both ports

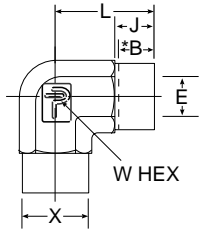
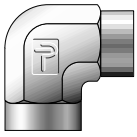

PART NO.	TUBE O.D. ₁	TUBE O.D. ₂	E SMALL BORE	*B	L	J	W HEX	X DIA.	WORK. PRES.
2 EW	1/8	1/8	.09	.156	.70	.34	1/2	.375	10,200
3 EW	3/16	3/16	.14	.203	.75	.39	1/2	.438	9,600
4 EW	1/4	1/4	.19	.250	.84	.44	9/16	.500	9,600
5 EW	5/16	5/16	.25	.313	.90	.50	9/16	.594	9,900
6-4 EW	3/8	1/4	.19	.344	1.08-.98	.53-.44	13/16	.63-.50	8,100
6 EW	3/8	3/8	.31	.344	1.08	.53	13/16	.625	8,100
8-4 EW	1/2	1/4	.19	.406	1.14-.98	.59-.44	7/8	.78-.50	7,300
8-6 EW	1/2	3/8	.31	.406	1.14-1.08	.59-.53	7/8	.78-.63	7,300
8 EW	1/2	1/2	.44	.406	1.14	.59	7/8	.781	7,300
10 EW	5/8	5/8	.50	.469	1.36	.66	1-1/16	.938	6,600
12 EW	3/4	3/4	.66	.500	1.39	.69	1-1/16	1.094	6,000
14 EW	7/8	7/8	.78	.500	1.58	.69	1-3/8	1.312	5,700
16 EW	1	1	.91	.563	1.84	.75	1-5/8	1.438	4,400
20 EW	1-1/4	1-1/4	1.06	.625	2.10	.81	1-7/8	1.750	4,600
24 EW	1-1/2	1-1/2	1.31	.670	2.54	.86	1-1/2	2.000	3,700
32 EW	2	2	1.81	.781	2.78	.97	2-13/16	2.625	3,300

*Socket Depth

45° Elbow

NW • tube socket – both ends

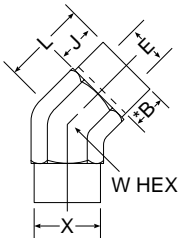

PART PART NO.	TUBE O.D.	TUBE O.D.	E SMALL BORE	L	X DIA.	W HEX	*B	J	WORK. PRES.
2 NW	1/8	1/8	.09	.53	.375	7/16	.156	.34	10,200
3 NW	3/16	3/16	.14	.73	.438	9/16	.203	.39	9,600
4 NW	1/4	1/4	.19	.84	.500	9/16	.250	.44	9,600
5 NW	5/16	5/16	.25	.86	.594	9/16	.313	.50	9,900
6 NW	3/8	3/8	.31	1.078	.625	7/8	.344	.53	8,100
8 NW	1/2	1/2	.44	1.14	.781	7/8	.406	.59	7,300
10 NW	5/8	5/8	.50	1.36	.938	1-1/16	.469	.66	6,600
12 NW	3/4	3/4	.66	1.34	1.094	1-1/16	.500	.69	6,000
16 NW	1	1	.91	1.63	1.438	1-5/8	.563	.75	4,400
20 NW	1-1/4	1-1/4	1.06	1.63	1.75	1-7/8	.625	.81	4,600
24 NW	1-1/2	1-1/2	1.31	1.67	2.00	2-1/2	.670	.86	3,700
32 NW	2	2	1.81	1.67	2.63	2-1/2	.781	.97	3,300

*Socket Depth

Tee

JW • tube socket end – all 3 ports

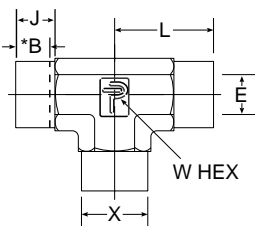
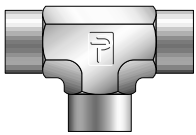

TUBE PART NO.	TUBE O.D. ₁	TUBE O.D. ₂	TUBE O.D. ₃	E SMALL BORE	*B	J	L	W HEX	X DIA.	WORK. PRES.
2 JW	1/8	1/8	1/8	.09	.156	.34	.70	1/2	.375	10,200
3 JW	3/16	3/16	3/16	.14	.203	.39	.75	1/2	.438	9,600
4 JW	1/4	1/4	1/4	.19	.250	.44	.84	9/16	.500	9,600
5 JW	5/16	5/16	5/16	.25	.313	.50	.90	9/16	.594	9,900
6-6-4 JW	3/8	3/8	1/4	.19	.34-.25	.53-.44	1.08-.99	13/16	.63-.50	8,100
6 JW	3/8	3/8	3/8	.31	.344	.53	1.08	13/16	.625	8,100
8-4-4 JW	1/2	1/4	1/4	.19	.41-.25	.59-.44	1.14-.98	7/8	.78-.50	7,300
8-6-6 JW	1/2	3/8	3/8	.31	.41-.34	.59-.53	1.14-1.08	7/8	.78-.63	7,300
8-8-4 JW	1/2	1/2	1/4	.19	.41-.25	.59-.44	1.14-.98	7/8	.78-.50	7,300
8-8-6 JW	1/2	1/2	3/8	.31	.41-.34	.59-.53	1.14-1.08	7/8	.78-.63	7,300
8 JW	1/2	1/2	1/2	.44	.406	.59	1.14	7/8	.781	7,300
10 JW	5/8	5/8	5/8	.50	.469	.66	1.36	1-1/16	.938	6,600
12-8-12 JW	3/4	1/2	3/4	.44	.50-.41	.69-.59	1.39-1.29	1-1/16	1.09-.78	6,000
12 JW	3/4	3/4	3/4	.66	.500	.69	1.39	1-1/16	1.094	6,000
14 JW	7/8	7/8	7/8	.78	.500	.69	1.58	1-3/8	1.312	5,700
16-8-16 JW	1	1.2	1	.44	.56-.41	.75-.59	1.84-1.68	1-5/8	1.44-.78	4,400
16-12-16 JW	1	3/4	1	.66	.56-.50	.75-.69	1.84-1.77	1-5/8	1.44-1.09	4,400
16 JW	1	1	1	.91	.563	.750	1.84	1-5/8	1.44	4,400
20-16-20 JW	1-1/4	1	1-1/4	.91	.63-.56	.81-.75	2.10-2.04	1-7/8	1.75-1.44	4,600
20 JW	1-1/4	1-1/4	1-1/4	1.06	.625	.812	2.102	1-7/8	1.750	4,600
24-16-24 JW	1-1/2	1	1-1/2	.91	.67-.56	.86-.75	2.54-2.44	2-1/2	2.00-1.44	3,700
24 JW	1-1/2	1-1/2	1-1/2	1.31	.670	.857	2.54	2-1/2	2.000	3,700
32 JW	2	2	2	1.81	.781	.968	2.78	2-13/16	2.625	3,300

*Socket Depth

NOTE: Other drop sizes available upon request.
Dimensions for reference only, subject to change.

Weld-lok® Socket Weld Tube Fittings

Cross

KW • tube socket end – all 4 ports

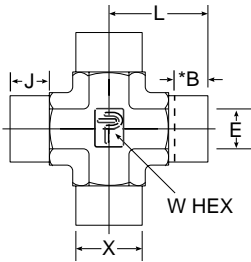
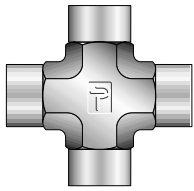

PART NO.	TUBE O.D.	E SMALL BORE	*B	J	L	W HEX	X DIA.	WORK. PRES.
2 KW	1/8	.09	1.56	.34	.70	1/2	.375	10,200
3 KW	3/16	.14	.203	.39	.75	1/2	.438	9,600
4 KW	1/4	.19	.250	.44	.84	9/16	.500	9,600
5 KW	5/16	.25	.313	.50	.90	9/16	.594	9,900
6 KW	3/8	.31	.344	.53	1.08	13/16	.625	8,100
8 KW	1/2	.44	.406	.59	1.14	13/16	.781	7,300
10 KW	5/8	.50	.469	.66	1.36	1-1/16	.938	6,600
12 KW	3/4	.66	.500	.69	1.39	1-1/16	1.094	6,000
16 KW	1	.91	.563	.75	1.84	1-5/8	1.438	4,400
20 KW	1-1/4	1.06	.625	.81	2.10	1-7/8	1.750	4,600
24 KW	1-1/2	1.31	.670	.86	2.54	2-9/16	2.000	3,700
32 KW	2	1.81	.781	.97	2.78	2-9/16	2.625	3,300

*Socket Depth

Male Elbow

CW • tube socket end – male pipe end

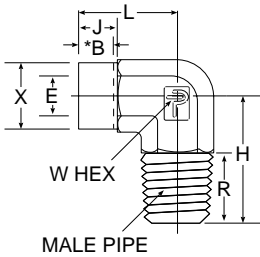
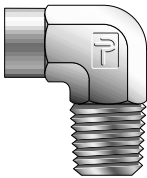

PART NO.	TUBE O.D. ₁	MALE PIPE	E SMALL BORE	*B	H	J	L	R	W HEX	X DIA.	WORK. PRES.
2 CW	1/8	1/8	.09	.156	.74	.34	.70	.38	1/2	.375	9,100
2-4 CW	1/8	1/4	.09	.156	.93	.34	.70	.56	1/2	.375	7,500
3 CW	3/16	1/8	.14	.203	.74	.39	.75	.38	1/2	.438	9,100
4 CW	1/4	1/8	.19	.250	.79	.44	.84	.38	9/16	.500	9,100
4-4 CW	1/4	1/4	.19	.250	.97	.44	.84	.56	9/16	.500	7,500
5 CW	5/16	1/8	.25	.313	.79	.50	.90	.38	9/16	.594	9,100
6 CW	3/8	1/4	.31	.344	1.12	.53	1.08	.56	13/16	.625	7,500
6-6 CW	3/8	3/8	.31	.344	1.12	.53	1.08	.56	13/16	.625	7,200
6-8 CW	3/8	1/2	.31	.344	1.31	.53	1.08	.75	13/16	.625	5,800
8-4 CW	1/2	1/4	.44	.406	1.12	.59	1.14	.56	7/8	.78	7,300
8 CW	1/2	3/8	.44	.406	1.12	.59	1.14	.56	7/8	.78	7,200
8-8 CW	1/2	1/2	.44	.406	1.31	.59	1.14	.75	13/16	.78	5,800
10 CW	5/8	1/2	.50	.469	1.46	.66	1.36	.75	1-1/16	.94	5,800
12-4 CW	3/4	1/4	.66	.500	1.27	.69	1.39	.56	1-1/16	1.09	6,000
12-8 CW	3/4	1/2	.66	.500	1.46	.69	1.39	.75	1-1/16	1.09	5,800
12 CW	3/4	3/4	.66	.500	1.46	.69	1.39	.75	1-1/16	1.09	6,000
16-12 CW	1	3/4	.72	.563	1.84	.75	1.84	.75	1-5/8	1.44	4,900
16 CW	1	1	.91	.563	2.03	.75	1.84	.94	1-5/8	1.44	4,400
20 CW	1-1/4	1-1/4	1.06	.625	2.27	.81	2.10	.97	1-7/8	1.750	3,500
24 CW	1-1/2	1-1/2	1.31	.670	2.69	.86	2.54	1.00	2-1/2	2.000	2,900

*Socket Depth

NOTE: Other drop sizes available upon request.
Dimensions for reference only, subject to change.

Male Connector

FW • tube socket end – male pipe end

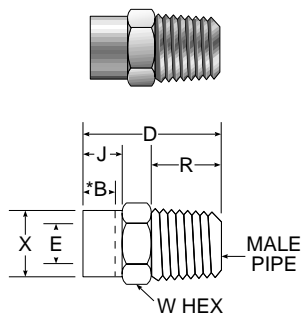

PART NO.	TUBE O.D.	MALE SOCK.	E SMALL BORE	*B	D	J	R	W HEX	X DIA.	WORK. PRES.
2 FW	1/8	1/8	.09	.156	.94	.34	.38	7/16	.375	9,100
2-4 FW	1/8	1/4	.09	.156	1.14	.34	.56	9/16	.375	7,500
3 FW	3/16	1/8	.14	.203	.94	.39	.38	1/2	.438	9,100
3-4 FW	3/16	1/4	.14	.203	1.19	.39	.56	9/16	.438	7,500
4 FW	1/4	1/8	.19	.250	1.05	.44	.38	9/16	.500	9,100
4-4 FW	1/4	1/4	.19	.250	1.23	.44	.56	9/16	.500	7,500
4-8 FW	1/4	1/2	.19	.250	1.50	.44	.75	7/8	.500	6,600
5 FW	5/16	1/8	.25	.313	1.13	.50	.38	5/8	.594	9,100
6-2 FW	3/8	1/8	.19	.344	1.16	.53	.38	11/16	.625	8,100
6 FW	3/8	1/4	.28	.344	1.34	.53	.56	11/16	.625	7,500
6-6 FW	3/8	3/8	.31	.344	1.34	.53	.56	11/16	.625	7,200
6-8 FW	3/8	1/2	.31	.344	1.59	.53	.75	7/8	.625	6,600
6-12 FW	3/8	3/4	.31	.344	1.66	.53	.75	1-1/16	.625	6,400
8-2 FW	1/2	1/8	.19	.406	1.25	.59	.38	13/16	.781	7,300
8-4 FW	1/2	1/4	.28	.406	1.44	.59	.56	13/16	.781	7,300
8 FW	1/2	3/8	.41	.406	1.44	.59	.56	13/16	.781	7,200
8-8 FW	1/2	1/2	.44	.406	1.66	.59	.75	7/8	.781	6,600
8-12 FW	1/2	3/4	.44	.406	1.72	.59	.75	1-1/16	.781	6,400
10-4 FW	5/8	1/4	.28	.469	1.56	.66	.56	1	.938	6,600
10-6 FW	5/8	3/8	.41	.469	1.56	.66	.56	1	.938	6,600
10 FW	5/8	1/2	.50	.469	1.75	.66	.75	1	.938	6,600
10-12 FW	5/8	3/4	.50	.469	1.78	.66	.75	1-1/16	.938	6,400
12-8 FW	3/4	1/2	.50	.500	1.81	.69	.75	1-1/8	1.094	6,000
12 FW	3/4	3/4	.66	.500	1.81	.69	.75	1-1/8	1.094	6,000
12-16 FW	3/4	1	.66	.500	2.09	.69	.94	1-3/8	1.094	4,600
14 FW	7/8	3/4	.66	.500	1.91	.69	.75	1-3/8	1.312	5,700
16-8 FW	1	1/2	.50	.563	2.02	.75	.75	1-5/8	1.438	4,900
16-12 FW	1	3/4	.72	.563	2.02	.75	.75	1-5/8	1.438	4,900
16 FW	1	1	.91	.563	2.20	.75	.94	1-5/8	1.438	4,600
20-12 FW	1-1/4	3/4	.72	.625	2.14	.81	.75	1-7/8	1.750	4,600
20-16 FW	1-1/4	1	.94	.625	2.33	.81	.94	1-7/8	1.750	4,600
20 FW	1-1/4	1-1/4	1.06	.625	2.36	.81	.97	1-7/8	1.750	3,500
20-24 FW	1-1/4	1-1/2	1.06	.625	2.42	.81	1.00	2	1.750	2,900
24-20 FW	1-1/2	1-1/4	1.25	.670	2.49	.86	.97	2-1/8	2.000	3,500
24 FW	1-1/2	1-1/2	1.31	.670	2.52	.86	1.00	2-1/8	2.000	2,900
32 FW	2	2	1.81	.781	2.97	.97	1.03	2-3/4	2.625	2,600

*Socket Depth

Female Connector

GW • tube socket end – female pipe end

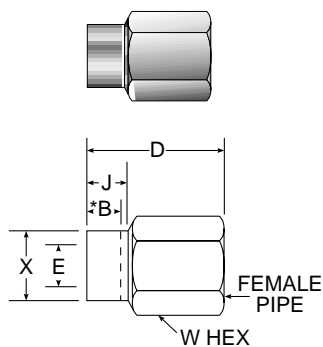

PART PART NO.	TUBE O.D.	FEMALE PIPE	E SMALL BORE	*B	D	J	W HEX	X DIA.	WORK. PRES.
2 GW	1/8	1/8	.09	.156	.95	.34	9/16	.375	6,400
3 GW	3/16	1/8	.14	.203	.98	.39	9/16	.438	6,400
4 GW	1/4	1/8	.19	.250	1.01	.44	9/16	.500	6,400
4-4 GW	1/4	1/4	.19	.250	1.26	.44	3/4	.500	6,600
4-12 GW	1/4	3/4	.19	.250	1.80	.44	1-1/4	.500	4,300
5 GW	5/16	1/8	.25	.313	1.07	.50	5/8	.594	6,400
6-2 GW	3/8	1/8	.31	.344	1.11	.53	11/16	.625	6,400
6 GW	3/8	1/4	.31	.344	1.32	.53	3/4	.625	6,600
6-6 GW	3/8	3/8	.31	.344	1.42	.53	15/16	.625	5,300
6-8 GW	3/8	1/2	.31	.344	1.67	.53	1-1/16	.625	5,200
6-12 GW	3/8	3/4	.31	.344	1.86	.53	1-1/4	.625	4,300
6-16 GW	3/8	1	.31	.344	2.30	.53	1-5/8	.625	4,500
8-2 GW	1/2	1/8	.34	.406	1.17	.59	13/16	.781	6,400
8-4 GW	1/2	1/4	.44	.406	1.36	.59	13/16	.781	6,600
8 GW	1/2	3/8	.44	.406	1.44	.59	7/8	.781	5,300
8-8 GW	1/2	1/2	.44	.406	1.69	.59	1-1/16	.781	5,200
10-6 GW	5/8	3/8	.50	.469	1.52	.66	1-1/16	.938	5,300
10 GW	5/8	1/2	.50	.469	1.71	.66	1-1/16	.938	5,200
10-16 GW	5/8	1	.50	.469	2.33	.66	1-5/8	.938	4,500
12-8 GW	3/4	1/2	.66	.500	1.72	.69	1-1/8	1.094	5,200
12 GW	3/4	3/4	.66	.500	1.88	.69	1-1/4	1.094	4,300
14 GW	7/8	3/4	.78	.500	1.86	.69	1-3/8	1.312	4,300
16-8 GW	1	1/2	.71	.563	1.85	.75	1-5/8	1.438	4,900
16-12 GW	1	3/4	.91	.563	1.97	.75	1-5/8	1.438	4,300
16 GW	1	1	.91	.563	2.28	.75	1-5/8	1.438	4,500
20 GW	1-1/4	1-1/4	1.06	.625	2.39	.81	2	1.750	3,500

*Socket Depth

NOTE: Other drop sizes available upon request.
Dimensions for reference only, subject to change.

Weld-lok® Socket Weld Tube Fittings

Female Elbow

DW • tube socket end – female pipe end

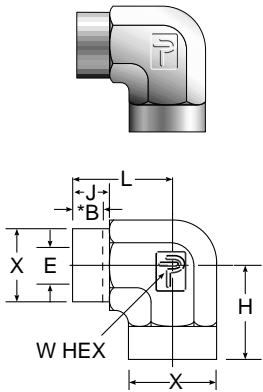

PART NO.	TUBE O.D.	FEMALE PIPE	E SMALL BORE	*B	H	J	L	W HEX	X DIA.	WORK. PRES.
2 DW	1/8	1/8	.09	.156	.75	.34	.70	1/2	.375	5,500
3 DW	3/16	1/8	.14	.203	.75	.39	.75	1/2	.438	5,500
4 DW	1/4	1/8	.19	.250	.75	.44	.84	9/16	.500	5,500
4-4 DW	1/4	1/4	.19	.250	.88	.44	.91	11/16	.500	5,600
5 DW	5/16	1/8	.25	.313	.75	.50	.90	9/16	.594	5,500
6 DW	3/8	1/4	.31	.344	.88	.53	1.00	11/16	.625	5,600
6-6 DW	3/8	3/8	.31	.344	.88	.53	1.08	13/16	.625	5,000
6-8 DW	3/8	1/2	.31	.344	1.12	.53	1.19	1	.625	4,500
8-4 DW	1/2	1/4	.44	.406	.88	.59	1.14	7/8	.781	5,600
8 DW	1/2	3/8	.44	.406	.88	.59	1.14	13/16	.781	5,000
8-8 DW	1/2	1/2	.44	.406	1.12	.59	1.29	1-1/16	.781	4,500
10 DW	5/8	1/2	.50	.469	1.12	.66	1.36	1-1/16	.938	4,500
12-4 DW	3/4	1/4	.66	.500	1.12	.69	1.39	1-1/16	1.094	5,600
12 DW	3/4	3/4	.66	.500	1.25	.69	1.58	1-5/16	1.094	3,500
14-12 DW	7/8	3/4	.78	.500	1.25	.69	1.58	1-3/8	1.312	3,500
16-6 DW	1	3/8	.91	.563	1.75	.75	1.84	1-5/8	1.438	4,900
16 DW	1	1	.91	.563	1.50	.75	1.84	1-5/8	1.438	3,900
20 DW	1-1/4	1-1/4	1.06	.625	1.88	.81	2.10	1-7/8	1.750	3,100
24-16 DW	1-1/2	1	1.31	.670	2.08	.86	2.54	2-1/2	2.000	3,700
24 DW	1-1/2	1-1/2	1.31	.670	2.13	.86	2.54	2-1/2	2.000	2,500

*Socket Depth

Male Run Tee

RW • socket weld – male run tee

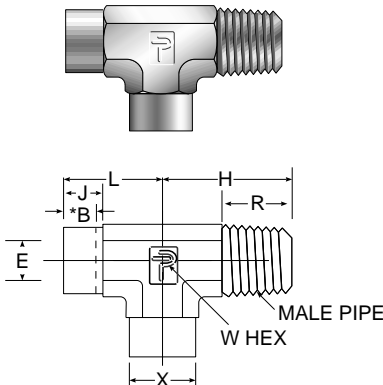

PART NO.	TUBE O.D.	MALE PIPE	E SMALL BORE	L	H	X DIA.	W HEX	*B	J	R	WORK. PRES.
2 RW	1/8	1/8	.09	.70	.74	.375	1/2	.156	.34	.38	9,100
3 RW	3/16	1/8	.14	.75	.75	.438	1/2	.203	.39	.38	9,100
4 RW	1/4	1/8	.19	.84	.79	.500	9/16	.250	.44	.38	9,100
5 RW	5/16	1/8	.19	.90	.79	.594	9/16	.313	.50	.38	9,100
6 RW	3/8	1/4	.28	1.08	1.12	.625	13/16	.344	.53	.56	7,500
8 RW	1/2	3/8	.41	1.14	1.12	.781	13/16	.406	.59	.56	7,200
10 RW	5/8	1/2	.50	1.36	1.46	.938	1-1/16	.469	.66	.75	5,800
12 RW	3/4	3/4	.656	1.39	1.46	1.094	1-1/16	.500	.69	.75	6,000
14 RW	7/8	3/4	.719	1.58	1.65	1.312	1-3/8	.500	.69	.75	5,700
16 RW	1	1	.906	1.84	2.03	1.438	1-5/16	.563	.75	.94	4,400
20 RW	1-1/4	1-1/4	1.063	2.10	2.27	1.750	1-7/8	.625	.81	.97	3,500
24 RW	1-1/2	1-1/2	1.313	2.54	2.70	2.000	2-1/2	.670	.86	1.00	2,900
32 RW	2	2	1.813	2.78	2.85	2.625	2-13/16	.781	.97	1.03	2,600

*Socket Depth

Male Branch Tee

SW • socket weld – male outlet tee

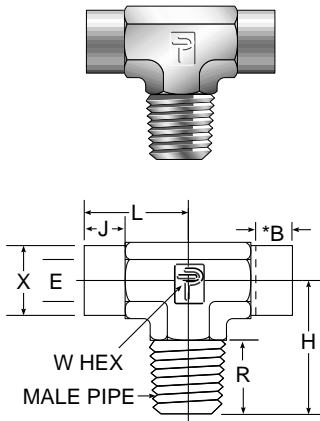

PART NO.	TUBE O.D.	MALE PIPE	E SMALL BORE	L	H	X DIA.	W HEX	*B	J	R	WORK. PRES.
2 SW	1/8	1/8	.09	.70	.74	.375	1/2	.156	.34	.38	9,100
3 SW	3/16	1/8	.14	.75	.75	.438	1/2	.203	.39	.38	9,100
4 SW	1/4	1/8	.19	.84	.79	.500	9/16	.250	.44	.38	9,100
5 SW	5/16	1/8	.19	.90	.79	.594	9/16	.313	.50	.38	9,100
6 SW	3/8	1/4	.28	1.08	1.12	.625	13/16	.344	.53	.56	7,500
8 SW	1/2	3/8	.41	1.14	1.12	.781	13/16	.406	.59	.56	7,200
10 SW	5/8	1/2	.50	1.36	1.47	.938	1-1/16	.469	.66	.75	5,800
12 SW	3/4	3/4	.66	1.39	1.46	1.094	1-1/16	.500	.69	.75	6,000
14 SW	7/8	3/4	.72	1.58	1.65	1.312	1-3/8	.500	.69	.75	5,700
16 SW	1	1	.91	1.84	2.03	1.438	1-5/16	.563	.75	.94	4,400
20 SW	1-1/4	1-1/4	1.06	2.10	2.27	1.750	1-7/8	.625	.81	.97	3,500
24 SW	1-1/2	1-1/2	1.31	2.54	2.70	2.000	2-1/2	.670	.86	1.00	2,900
32 SW	2	2	1.81	2.78	2.85	2.625	2-13/16	.781	.97	1.03	2,600

*Socket Depth

NOTE: Other drop sizes available upon request.
Dimensions for reference only, subject to change.

Adapter

AW • tube socket end – adapter end for welding into a female pipe size welding boss

TYPE I

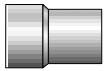

TYPE II

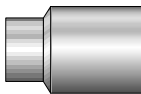

TYPE I

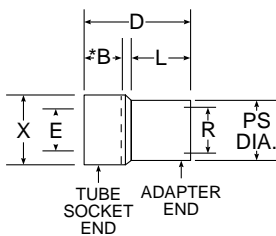

TYPE II

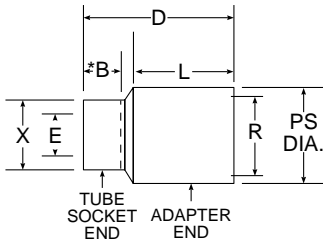

PART NO.	TYPE	TUBE O.D.	PIPE SIZE	PIPE SIZE O.D.	R BORE	X DIA.	L	D	*B	E BORE	WORK. PRES.
2-1/8 AW	II	1/8	1/8	.41	.21	.38	.38	.73	.16	.09	8,700
2-1/4 AW	II	1/8	1/4	.54	.30	.38	.56	.95	.16	.09	8,200
3-1/8 AW	I	3/16	1/8	.41	.21	.44	.38	.76	.20	.14	8,700
3-1/2 AW	II	3/16	1/2	.84	.55	.44	.75	1.26	.20	.14	6,400
3-3/4 AW	I	3/16	3/4	1.05	.73	.44	.75	1.32	.20	.14	5,300
4-1/8 AW	I	1/4	1/8	.41	.21	.50	.38	.84	.25	.19	8,700
4-1/4 AW	II	1/4	1/4	.54	.30	.50	.56	1.01	.25	.19	8,200
4-3/8 AW	II	1/4	3/8	.68	.42	.50	.56	1.05	.25	.19	6,900
4-1/2 AW	II	1/4	1/2	.84	.55	.50	.75	1.29	.25	.19	6,400
4-3/4 AW	II	1/4	3/4	1.05	.73	.50	.75	1.35	.25	.19	5,300
4-1 AW	II	1/4	1	1.31	.95	.50	.94	1.61	.25	.19	4,900
5-1/8 AW	I	5/16	1/8	.41	.21	.59	.38	.93	.31	.21	8,700
5-1/2 AW	II	5/16	1/2	.84	.55	.59	.75	1.32	.31	.25	6,400
6-1/4 AW	I	3/8	1/4	.54	.30	.63	.56	1.12	.34	.30	8,100
6-3/8 AW	II	3/8	3/8	.68	.42	.63	.56	1.11	.34	.31	6,900
6-1/2 AW	II	3/8	1/2	.84	.55	.63	.75	1.34	.34	.31	6,400
6-3/4 AW	II	3/8	3/4	1.05	.73	.63	.75	1.40	.34	.31	5,300
6-1 AW	II	3/8	1	1.31	.95	.63	.94	1.67	.34	.31	4,900
6-1-1/2 AW	II	3/8	1-1/2	1.50	1.50	.63	1.03	1.93	.34	.31	3,700
8-1/4 AW	I	1/2	1/4	.54	.30	.78	.56	1.23	.41	.30	8,100
8-3/8 AW	I	1/2	3/8	.68	.41	.78	.56	1.19	.41	.41	6,900
8-1/2 AW	II	1/2	1/2	.84	.55	.78	.75	1.36	.41	.44	6,400
8-3/4 AW	II	1/2	3/4	1.05	.73	.78	.75	1.42	.41	.44	5,300
8-1 AW	II	1/2	1	1.31	.95	.78	.94	1.69	.41	.44	4,900
10-1/2 AW	I	5/8	1/2	.84	.55	.94	.75	1.43	.47	.50	4,900
10-3/4 AW	II	5/8	3/4	1.05	.73	.94	.75	1.44	.47	.50	5,300
10-1 AW	II	5/8	1	1.31	.95	.94	.94	1.70	.47	.50	4,900
12-1/4 AW	I	3/4	1/4	.54	.30	1.09	.56	1.41	.50	.30	6,000
12-3/8 AW	I	3/4	3/8	.68	.42	1.09	.56	1.37	.50	.42	6,000
12-1/2 AW	I	3/4	1/2	.84	.55	1.09	.75	1.51	.50	.55	6,000
12-3/4 AW	I	3/4	3/4	1.05	.73	1.09	.75	1.45	.50	.66	5,300
12-1 AW	II	3/4	1	1.31	.95	1.09	.94	1.69	.50	.66	4,900
16-1/4 AW	I	1	1/4	.54	.30	1.44	.56	1.57	.56	.30	4,900
16-3/8 AW	I	1	3/8	.68	.42	1.44	.56	1.53	.56	.42	4,900
16-1/2 AW	I	1	1/2	.84	.55	1.44	.75	1.67	.56	.55	4,900
16-3/4 AW	I	1	3/4	1.05	.73	1.44	.75	1.61	.56	.73	4,900
16-1 AW	I	1	1	1.31	.95	1.44	.94	1.72	.56	.91	4,900
16-1-1/4 AW	II	1	1-1/4	1.66	1.28	1.44	.94	1.75	.56	.91	4,100
16-1-1/2 AW	II	1	1-1/2	1.90	1.50	1.44	1.03	1.91	.56	.91	3,700
20-1-1/4 AW	II	1-1/4	1-1/4	1.66	1.28	1.75	.94	1.78	.63	1.06	4,100
20-1-1/2 AW	II	1-1/4	1-1/2	1.90	1.50	1.75	1.03	1.89	.63	1.06	3,700
24-1-1/2 AW	I	1-1/2	1-1/2	1.90	1.50	2.00	1.03	1.92	.67	1.31	3,700
32-2 AW	I	2	2	2.38	1.94	2.63	1.06	2.10	.78	1.81	3,200

NOTE: "R" bore diameter will conform to Schedule 80 pipe wall thickness unless otherwise noted.

*Socket Depth

NOTE: Other drop sizes available upon request.
Dimensions for reference only, subject to change.

Weld-lok® Socket Weld Tube Fittings

Adapter

AW2 • tube socket to pipe butt weld

TYPE I

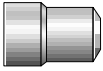

TYPE II

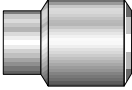

TYPE I

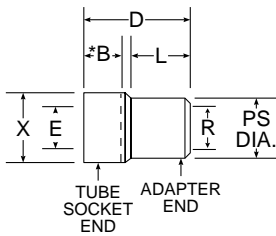

TYPE II

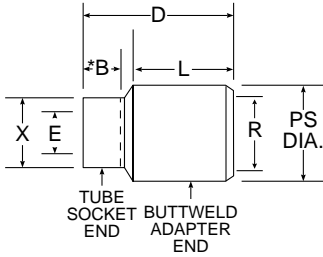

PART NO.	TYPE	TUBE O.D.	PIPE SIZE	PIPE SIZE O.D.	R BORE	X DIA.	L	D	*B	E BORE	WORK. PRES.
2-1/8 AW2	II	1/8	1/8	.41	.21	.38	.38	.73	.16	.09	8,700
2-1/4 AW2	II	1/8	1/4	.54	.30	.38	.56	.95	.16	.09	8,200
3-1/8 AW2	I	3/16	1/8	.41	.21	.44	.38	.76	.20	.14	8,700
3-1/2 AW2	II	3/16	1/2	.84	.55	.44	.75	1.26	.20	.14	6,400
3-3/4 AW2	II	3/16	3/4	1.05	.73	.44	.75	1.32	.20	.14	5,300
4-1/8 AW2	I	1/4	1/8	.41	.21	.50	.38	.84	.25	.19	8,700
4-1/4 AW2	II	1/4	1/4	.54	.30	.50	.56	1.01	.25	.19	8,200
4-3/8 AW2	II	1/4	3/8	.68	.42	.50	.56	1.05	.25	.19	6,900
4-1/2 AW2	II	1/4	1/2	.84	.55	.50	.75	1.29	.25	.19	6,400
4-3/4 AW2	II	1/4	3/4	1.05	.73	.50	.75	1.35	.25	.19	5,300
4-1 AW2	II	1/4	1	1.31	.95	.50	.94	1.61	.25	.19	4,900
5-1/8 AW2	I	5/16	1/8	.41	.21	.59	.38	.93	.31	.21	8,700
5-1/2 AW2	II	5/16	1/2	.84	.55	.59	.75	1.32	.31	.25	6,400
6-1/4 AW2	I	3/8	1/4	.54	.30	.63	.56	1.12	.34	.30	8,100
6-3/8 AW2	II	3/8	3/8	.68	.42	.63	.56	1.11	.34	.31	6,900
6-1/2 AW2	II	3/8	1/2	.84	.55	.63	.75	1.34	.34	.31	6,400
6-3/4 AW2	II	3/8	3/4	1.05	.73	.63	.75	1.40	.34	.31	5,300
6-1 AW2	II	3/8	1	1.31	.95	.63	.94	1.67	.34	.31	4,900
6-1-1/2 AW2	II	3/8	1-1/2	1.50	1.50	.63	1.03	1.93	.34	.31	3,700
8-1/4 AW2	I	1/2	1/4	.54	.30	.78	.56	1.23	.41	.30	8,100
8-3/8 AW2	I	1/2	3/8	.68	.41	.78	.56	1.19	.41	.41	6,900
8-1/2 AW2	II	1/2	1/2	.84	.55	.78	.75	1.36	.41	.44	6,400
8-3/4 AW2	II	1/2	3/4	1.05	.78	.75	1.42	.41	.44	.44	5,300
8-1 AW2	II	1/2	1	1.31	.95	.78	.94	1.69	.41	.44	4,900
10-1/2 AW2	I	5/8	1/2	.54	.30	.94	.75	1.43	.47	.50	4,900
10-3/4 AW2	II	5/8	3/4	1.05	.73	.94	.75	1.44	.47	.50	5,300
10-1 AW2	II	5/8	1	1.31	.95	.94	.94	1.70	.47	.50	4,900
12-1/4 AW2	I	3/4	1/4	.54	.30	1.09	.56	1.41	.50	.30	6,000
12-3/8 AW2	I	3/4	3/8	.68	.42	1.09	.56	1.37	.50	.42	6,000
12-1/2 AW2	I	3/4	1/2	.84	.55	1.09	.75	1.51	.50	.55	6,000
12-3/4 AW2	I	3/4	3/4	1.05	.73	1.09	.75	1.45	.50	.66	5,300
12-1 AW2	II	3/4	1	1.31	.95	1.09	.94	1.69	.50	.66	4,900
16-1/4 AW2	I	1	1/4	.54	.30	1.44	.56	1.57	.56	.30	4,900
16-3/8 AW2	I	1	3/8	.68	.42	1.44	.56	1.53	.56	.42	4,900
16-1/2 AW2	I	1	1/2	.84	.55	1.44	.75	1.67	.56	.55	4,900
16-3/4 AW2	I	1	3/4	1.05	.73	1.44	.75	1.61	.56	.73	4,900
16-1 AW2	I	1	1	1.31	.95	1.44	.94	1.72	.56	.91	4,900
16-1-1/4 AW2	II	1	1-1/4	1.66	1.28	1.44	.94	1.75	.56	.91	4,100
16-1-1/2 AW2	II	1	1-1/2	1.90	1.50	1.44	1.03	1.91	.56	.91	3,700
20-1-1/4 AW2	II	1-1/4	1-1/4	1.66	1.28	1.75	.94	1.78	.63	1.06	4,100
20-1-1/2 AW2	II	1-1/4	1-1/2	1.90	1.50	1.75	1.03	1.89	.63	1.06	3,700
24-1-1/2 AW2	I	1-1/2	1-1/2	1.90	1.50	2.00	1.03	1.92	.67	1.31	3,700
32-2 AW2	I	2	2	2.38	1.94	2.63	1.06	2.10	.78	1.81	3,200

NOTE: "R" bore diameter will conform to Schedule 80 pipe wall thickness unless otherwise noted.

*Socket Depth

NOTE: Other drop sizes available upon request.
Dimensions for reference only, subject to change.

ZHBW

Socket weld connector for fractional tube

- for CPI™ to tubing socket weld connection

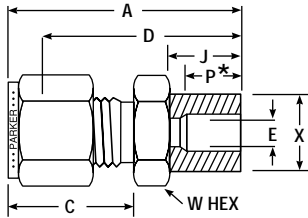
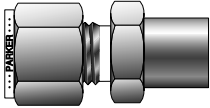

PART NO.	INTER-CHANGES WITH	TUBE O.D.	A	C	D	J	*P	X	E BORE	W HEX
1-2 ZHBW	100-6-2W	1/16	.99	.43	.84	.34	.16	.38	.09	7/16
1-4 ZHBW	100-6-4W	1/16	1.10	.43	.95	.44	.25	.50	.19	9/16
2-2 ZHBW	200-6-2W	1/8	1.16	.60	.90	.34	.16	.38	.09	7/16
3-3 ZHBW	300-6-3W	3/16	1.25	.64	.98	.39	.20	.44	.13	1/2
4-4 ZHBW	400-6-4W	1/4	1.37	.70	1.08	.44	.25	.50	.19	9/16
4-6 ZHBW	400-6-6W	1/4	1.47	.70	1.18	.53	.34	.63	.31	11/16
4-8 ZHBW	400-6-8W	1/4	1.56	.70	1.27	.59	.41	.78	.44	13/16
4-10 ZHBW	400-6-10W	1/4	1.60	.70	1.31	.66	.47	.94	.50	1
4-12 ZHBW	400-6-12W	1/4	1.75	.70	1.46	.69	.50	1.09	.66	1-1/8
4-16 ZHBW	400-6-16W	1/4	1.88	.70	1.59	.75	.56	1.38	.91	1-1/2
6-2 ZHBW	600-6-2W	3/8	1.35	.76	1.06	.34	.16	.38	.09	5/8
6-6 ZHBW	600-6-6W	3/8	1.53	.76	1.24	.53	.34	.63	.28	11/16
6-8 ZHBW	600-6-8W	3/8	1.63	.76	1.34	.59	.41	.78	.44	13/16
6-12 ZHBW	600-6-12W	3/8	1.81	.76	1.52	.69	.50	1.09	.66	1-1/8
6-16 ZHBW	600-6-16W	3/8	2.02	.76	1.73	.75	.56	1.44	.91	1-5/8
8-2 ZHBW	800-6-2W	1/2	1.49	.87	1.09	.34	.16	.38	.09	13/16
8-4 ZHBW	800-6-4W	1/2	1.58	.87	1.18	.44	.25	.50	.19	13/16
8-6 ZHBW	800-6-6W	1/2	1.67	.87	1.27	.53	.34	.63	.31	13/16
8-8 ZHBW	800-6-8W	1/2	1.74	.87	1.34	.59	.41	.78	.41	13/16
8-12 ZHBW	800-6-12W	1/2	1.92	.87	1.52	.69	.50	1.09	.66	1-1/8
8-16 ZHBW	800-6-16W	1/2	2.53	.87	1.73	.75	.56	1.44	.91	1-5/8
10-10 ZHBW	1010-6-10W	5/8	1.86	.87	1.46	.66	.47	.94	.50	1
10-12 ZHBW	1010-6-12W	5/8	1.92	.87	1.52	.69	.50	1.09	.66	1-1/8
12-4 ZHBW	1210-6-4W	3/4	1.68	.87	1.28	.44	.25	.50	.19	1-1/16
12-8 ZHBW	1210-6-8W	3/4	1.84	.87	1.44	.59	.41	.78	.44	1-1/16
12-12 ZHBW	1210-6-12W	3/4	1.92	.87	1.52	.69	.50	1.09	.63	1-1/8
12-16 ZHBW	1210-6-16W	3/4	2.13	.87	1.73	.75	.56	1.44	.91	1-5/8
16-4 ZHBW	1610-6-4W	1	1.95	1.05	1.46	.44	.25	.50	.19	1-3/8
16-6 ZHBW	1610-6-6W	1	2.05	1.05	1.56	.53	.34	.63	.31	1-3/8
16-12 ZHBW	1610-6-12W	1	2.20	1.05	1.71	.69	.50	1.09	.66	1-3/8
16-16 ZHBW	1610-6-16W	1	2.31	1.05	1.82	.75	.56	1.44	.88	1-5/8
16-20 ZHBW	1610-6-20W	1	2.43	1.05	1.94	.81	.63	1.75	.88	1-7/8
20-16 ZHBW	2000-6-16W	1-1/4	2.81	1.52	1.95	.75	.56	1.44	.91	1-3/4
20-20 ZHBW	2000-6-20W	1-1/4	2.90	1.52	2.04	.81	.63	1.75	1.09	1-7/8
24-12 ZHBW	2400-6-12W	1-1/2	3.15	1.77	2.09	.69	.50	1.09	.66	2-1/8
24-20 ZHBW	2400-6-20W	1-1/2	3.27	1.77	2.21	.81	.63	1.75	1.06	2-1/8
24-24 ZHBW	2400-6-24W	1-1/2	3.32	1.77	2.26	.86	.67	2.00	1.31	2-1/8
32-32 ZHBW	3200-6-32W	2	4.40	2.47	2.93	.97	.78	2.63	1.81	2-3/4

NOTE: A and C dimensions are typical finger-tight.

Dimensions for reference only, subject to change.

For A-LOK® tube fitting double ferrule system replace "B" (ZHBW) with a "L" (ZHLW)

*Socket Depth

Weld-lok® To Compression

ZHBW2

Buttweld connector for fractional pipe

• for CPI™ to pipe buttweld connection

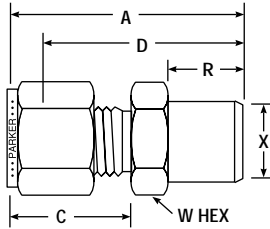
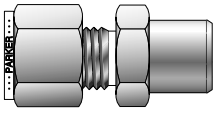

PART NO.	INTER-CHANGES WITH	TUBE O.D.	BUTT WELD PIPE SIZE	A	C	D	R	X	BUTT WELD O.D.	W HEX
1-1/8 ZHBW2	00-1-2W	1/16	1/8	1.03	.43	.88	.38	.41	7/16	7/16
2-1/8 ZHBW2	200-1-2W	1/8	1/8	1.20	.60	.94	.38	.41	7/16	7/16
2-1/4 ZHBW2	200-1-4W	1/8	1/4	1.40	.60	1.14	.56	.54	9/16	9/16
2-1/2 ZHBW2	200-1-8W	1/8	1/2	1.67	.60	1.41	.75	.84	7/8	7/8
3-1/8 ZHBW2	300-1-2W	3/16	1/8	1.24	.64	.97	.38	.41	7/16	7/16
4-1/8 ZHBW2	400-1-2W	1/4	1/8	1.29	.70	1.00	.38	.41	1/2	1/2
4-1/4 ZHBW2	400-1-4W	1/4	1/4	1.50	.70	1.20	.56	.54	5/8	5/8
4-3/8 ZHBW2	400-1-6W	1/4	3/8	1.54	.70	1.25	.56	.68	3/4	3/4
4-1/2 ZHBW2	400-1-8W	1/4	1/2	1.76	.70	1.47	.75	.84	7/8	7/8
4-3/4 ZHBW2	400-1-12W	1/4	3/4	1.82	.70	1.53	.75	1.05	1-1/8	1-1/8
4-1 ZHBW2	400-1-16W	1/4	1	2.10	.70	1.81	.94	1.32	1-3/8	1-3/8
5-1/8 ZHBW2	500-1-2W	5/16	1/8	1.34	.73	1.05	.38	.41	9/16	9/16
5-1/4 ZHBW2	500-1-4W	5/16	1/4	1.52	.73	1.23	.56	.54	9/16	9/16
5-1/2 ZHBW2	500-1-8W	5/16	1/2	1.79	.73	1.500	.75	.84	7/8	7/8
6-1/4 ZHBW2	600-1-4W	3/8	1/4	1.57	.76	1.28	.56	.54	5/8	5/8
6-3/8 ZHBW2	600-1-6W	3/8	3/8	1.57	.76	1.28	.56	.68	3/4	3/4
6-1/2 ZHBW2	600-1-8W	3/8	1/2	1.82	.76	1.53	.75	.84	7/8	7/8
6-3/4 ZHBW2	600-1-12W	3/8	3/4	1.88	.76	1.59	.75	1.05	1-1/8	1-1/8
6-1 ZHBW2	600-1-16W	3/8	1	2.17	.76	1.88	.94	1.32	1-3/8	1-3/8
6-1-1/2 ZHBW2	600-1-24W	3/8	1-1/2	2.39	.76	2.10	1.03	1.90	2	2
6-2 ZHBW2	600-1-32W	3/8	2	2.58	.76	2.29	1.06	2.38	2-1/2	2-1/2
8-1/8 ZHBW2	810-1-2W	1/2	1/8	1.53	.87	1.13	.38	.41	13/16	13/16
8-1/4 ZHBW2	810-1-4W	1/2	1/4	1.71	.87	1.31	.56	.54	13/16	13/16
8-3/8 ZHBW2	810-1-6W	1/2	3/8	1.71	.87	1.31	.56	.68	13/16	13/16
8-1/2 ZHBW2	810-1-8W	1/2	1/2	1.93	.87	1.53	.75	.84	7/8	7/8
8-3/4 ZHBW2	810-1-12W	1/2	3/4	1.99	.87	1.59	.75	1.05	1-1/8	1-1/8
8-1 ZHBW2	81-1-16W	1/2	1	2.28	.87	1.88	.94	1.32	1-3/8	1-3/8
8-1-1/2 ZHBW2	810-1-24W	1/2	1-1/2	2.50	.87	2.10	1.03	1.90	2	2
10-1/4 ZHBW2	1010-1-4W	5/8	1/4	1.74	.87	1.34	.56	.54	15/16	15/16
10-3/8 ZHBW2	1010-1-6W	5/8	3/8	1.74	.87	1.34	.56	.67	15/16	15/16
10-1/2 ZHBW2	1010-1-8W	5/8	1/2	1.93	.87	1.53	.75	.84	15/16	15/16
10-3/4 ZHBW2	1010-1-12W	5/8	3/4	1.99	.87	1.59	.75	1.05	1-1/8	1-1/8
12-3/8 ZHBW2	1210-1-6W	3/4	3/8	1.81	.87	1.41	.56	.67	1-1/8	1-1/8
12-1/2 ZHBW2	1210-1-8W	3/4	1/2	1.99	.87	1.59	.75	.84	1-1/8	1-1/8
12-3/4 ZHBW2	1210-1-12W	3/4	3/4	1.99	.87	1.59	.75	1.05	1-1/8	1-1/8
12-1 ZHBW2	1210-1-16W	3/4	1	2.28	.87	1.88	.94	1.32	1-3/8	1-3/8
16-1/2 ZHBW2	1610-1-8W	1	1/2	2.18	1.05	1.78	.75	.84	1-3/8	1-3/8
16-3/4 ZHBW2	1610-1-12W	1	3/4	2.27	1.05	1.78	.75	1.05	1-3/8	1-3/8
16-1 ZHBW2	1610-1-16W	1	1	2.46	1.05	1.97	.94	1.32	1-3/8	1-3/8
16-1-1/4 ZHBW2	1610-1-20W	1	1-1/4	2.56	1.05	2.07	.94	1.66	1-3/4	1-3/4
16-1-1/2 ZHBW2	1610-1-24W	1	1-1/2	2.68	1.05	2.19	1.03	1.90	2	2
20-1 ZHBW2	2000-1-16W	1-1/4	1	3.06	1.52	2.20	.94	1.32	1-3/4	1-3/4
20-1-1/4 ZHBW2	2000-1-20W	1-1/4	1-1/4	3.03	1.52	2.17	.94	1.66	1-3/4	1-3/4
20-1-1/2 ZHBW2	2000-1-24W	1-1/4	1-1/2	3.16	1.52	2.30	1.03	1.90	2	2
24-1 ZHBW2	2400-1-16W	1-1/2	1	3.50	1.77	2.44	.94	1.32	2-1/8	2-1/8
24-1-1/4 ZHBW2	2400-1-20W	1-1/2	1-1/4	3.36	1.77	2.30	.94	1.66	2-1/8	2-1/8
24-1-1/2 ZHBW2	2400-1-24W	1-1/2	1-1/2	3.50	1.77	2.44	1.03	1.90	2-1/8	2-1/8
32-2 ZHBW2	3200-1-32W	2	2	4.47	2.47	3.00	1.06	2.38	2-3/4	2-3/4

NOTE: A and C dimensions are typical finger-tight.

Dimensions for reference only, subject to change.

Pipe Buttweld end will conform to Schedule 80 unless otherwise noted.

For A-LOK® tube fitting double ferrule system replace "B" (ZHBW2) with a "L" (ZHLW2)

ZEBW

For fractional tube

- for CPI™ to tubing socket weld connection

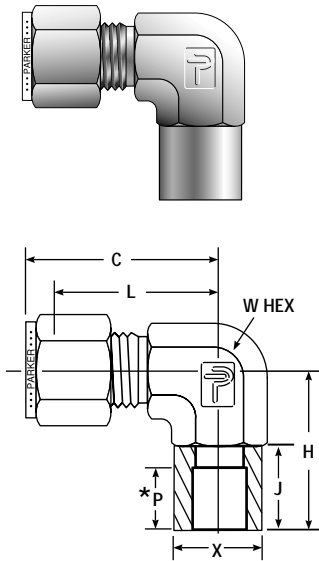

PART NO.	INTERCHANGES WITH	TUBE O.D.	C	L	H	J	*P	X DIA.	W HEX
2-2 ZEBW	200-9-2W	1/8	.93	.70	.70	.34	.16	.38	1/2
3-3 ZEBW	300-9-3W	3/16	1.01	.74	.75	.39	.20	.44	1/2
4-4 ZEBW	400-9-4W	1/4	1.07	.78	.78	.44	.25	.50	9/16
6-6 ZEBW	600-9-6W	3/8	1.31	1.02	1.08	.53	.34	.63	3/4
6-12 ZEBW	600-9-12W	3/8	1.46	1.17	1.39	.69	.50	1.09	1-1/16
6-16 ZEBW	600-9-16W	3/8	1.84	1.55	1.84	.75	.56	1.44	1-5/8
8-4 ZEBW	800-9-4W	1/2	1.42	1.02	.99	.44	.25	.50	13/16
8-8 ZEBW	800-9-8W	1/2	1.42	1.02	1.14	.59	.41	.78	13/16
8-10 ZEBW	800-9-10W	1/2	1.57	1.17	1.36	.66	.47	.94	1-1/16
8-12 ZEBW	800-9-12W	1/2	1.57	1.17	1.34	.69	.50	1.09	1-1/16
8-16 ZEBW	800-9-16W	1/2	1.95	1.55	1.84	.75	.56	1.44	1-5/8
10-6 ZEBW	1010-9-6W	5/8	1.50	1.10	1.16	.53	.34	.63	15/16
10-8 ZEBW	1010-9-8W	5/8	1.50	1.10	1.22	.59	.41	.78	15/16
10-10 ZEBW	1010-9-10W	5/8	1.57	1.17	1.36	.66	.47	.94	1-1/16
10-16 ZEBW	1010-9-16W	5/8	1.95	1.55	1.84	.75	.56	1.44	1-5/8
12-12 ZEBW	1210-9-12W	3/4	1.57	1.17	1.39	.69	.50	1.09	1-1/16
14-12 ZEBW	1410-9-12W	7/8	1.76	1.36	1.58	.69	.50	1.09	1-3/8
16-14 ZEBW	1610-9-14W	1	1.94	1.45	1.58	.69	.50	1.31	1-3/8
16-16 ZEBW	1610-9-16W	1	2.14	1.65	1.84	.75	.56	1.44	1-5/8

NOTE: C dimension is typical finger-tight. Dimensions for reference only, subject to change. For A-LOK® tube fitting double ferrule system replace "B" (ZEBW) with a "L" (ZHLW)

*Socket Depth

ZEBW2

Buttweld elbow for fractional pipe

- for CPI™ to pipe connection

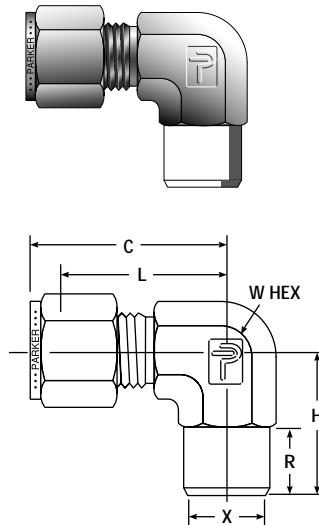

PART NO.	INTERCHANGES WITH	TUBE O.D.	BUTT WELD PIPE SIZE	C	H	L	R	X BUTT WELD O.D.	W HEX
2-1/8 ZEBW2	200-2-2W	1/8	1/8	.93	.70	.67	.38	.41	7/16
3-1/8 ZEBW2	300-2-2W	3/16	1/8	1.01	.74	.74	.38	.41	1/2
4-1/8 ZEBW2	400-2-2W	1/4	1/8	1.06	.74	.77	.38	.41	1/2
4-1/4 ZEBW2	400-2-4W	1/4	1/4	1.10	.97	.81	.56	.54	9/16
4-3/4 ZEBW2	400-2-12W	1/4	3/4	1.40	1.45	1.11	.75	1.05	1-1/16
6-1/4 ZEBW2	600-2-4W	3/8	1/4	1.20	1.00	.91	.56	.54	5/8
6-3/8 ZEBW2	600-2-6W	3/8	3/8	1.31	1.11	1.02	.56	.68	13/16
6-1/2 ZEBW2	600-2-8W	3/8	1/2	1.31	1.30	1.02	.75	.84	7/8
6-3/4 ZEBW2	600-2-12W	3/8	3/4	1.46	1.45	1.17	.75	1.05	1-1/16
6-1 ZEBW2	600-2-16W	3/8	1	1.65	1.83	1.36	.94	1.32	1-3/8
8-1/4 ZEBW2	810-2-4W	1/2	1/4	1.42	1.11	1.02	.56	.54	13/16
8-3/8 ZEBW2	810-2-6W	1/2	3/8	1.42	1.11	1.02	.56	.68	13/16
8-1/2 ZEBW2	810-2-8W	1/2	1/2	1.42	1.30	1.02	.75	.84	7/8
8-3/4 ZEBW2	810-2-12W	1/2	3/4	1.57	1.45	1.17	.75	1.05	1-1/16
8-1 ZEBW2	810-W-16W	1/2	1	1.76	1.86	1.36	.94	1.32	1-3/8
10-1/2 ZEBW2	1010-2-8W	5/8	1/2	1.50	1.39	1.10	.75	.84	15/16
12-1/2 ZEBW2	1210-2-8W	3/4	1/2	1.66	1.45	1.26	.75	.84	1-1/16
12-3/4 ZEBW2	1210-2-12W	3/4	3/4	1.57	1.45	1.17	.75	1.05	1-1/16
14-3/4 ZEBW2	1410-2-12W	7/8	3/4	1.78	1.64	1.36	.75	1.05	1-3/8
14-1 ZEBW2	1410-W-16W	7/8	1	1.78	1.83	1.36	.94	1.32	1-3/8
16-1/2 ZEBW2	1610-2-8W	1	1/2	1.94	1.64	1.45	.75	.84	1-3/8
16-3/4 ZEBW2	1610-2-12W	1	3/4	1.94	1.64	1.45	.75	1.05	1-3/8
16-1 ZEBW2	1610-2-16W	1	1	1.94	1.83	1.45	.94	1.32	1-3/8
16-1-1/4 ZEBW2	1610-2-20W	1	1-1/4	2.14	1.88	1.65	.94	1.66	1-5/8
20-1-1/4 ZEBW2	2000-2-20W	1-1/4	1-1/4	2.61	2.02	1.75	.94	1.66	1-5/8
24-1-1/2 ZEBW2	2400-2-24W	1-1/2	1-1/2	3.06	2.38	2.00	1.03	1.90	1-7/8

NOTE: C dimension is typical finger-tight. Dimensions for reference only, subject to change. Pipe buttweld end will conform to Schedule 80 unless otherwise noted.

For A-LOK® tube fitting double ferrule system replace "B" (ZEBW2) with a "L" (ZELW2)

Offer of Sale

The items described in this document and other documents or descriptions provided by Parker Hannifin Corporation, its subsidiaries and its authorized distributors are hereby offered for sale at prices to be established by Parker Hannifin Corporation, its subsidiaries and its authorized distributors. This offer and its acceptance by any customer ("Buyer") shall be governed by all of the following Terms and Conditions. Buyer's order for any such items, when communicated to Parker Hannifin Corporation, its subsidiary or an authorized distributor ("Seller") verbally or in writing, shall constitute acceptance of this offer.

1. Terms and Conditions of Sale: All descriptions, quotations, proposals, offers, acknowledgments, acceptances and sales of Seller's products are subject to and shall be governed exclusively by the terms and conditions stated herein. Buyer's acceptance of any offer to sell is limited to these terms and conditions. Any terms or conditions in addition to, or inconsistent with those stated herein, proposed by Buyer in any acceptance of an offer by Seller, are hereby objected to. No such additional, different or inconsistent terms and conditions shall become part of the contract between Buyer and Seller unless expressly accepted in writing by Seller. Seller's acceptance of any offer to purchase by Buyer is expressly conditional upon Buyer's assent to all the terms and conditions stated herein, including any terms in addition to, or inconsistent with those contained in Buyer's offer. Acceptance of Seller's products shall in all events constitute such assent.

2. Payment: Payment shall be made by Buyer net 30 days from the date of delivery of the items purchased hereunder. Amounts not timely paid shall bear interest at the maximum rate permitted by law for each month or portion thereof that the Buyer is late in making payment. Any claims by Buyer for omissions or shortages in a shipment shall be waived unless Seller receives notice thereof within 30 days after Buyer's receipt of the shipment.

3. Delivery: Unless otherwise provided on the face hereof, delivery shall be made F.O.B. Seller's plant. Regardless of the method of delivery, however, risk of loss shall pass to Buyer upon Seller's delivery to a carrier. Any delivery dates shown are approximate only and Seller shall have no liability for any delays in delivery.

4. Warranty: Seller warrants that items sold hereunder shall be free from defects in material or workmanship. **THIS WARRANTY COMPRISES THE SOLE AND ENTIRE WARRANTY PERTAINING TO ITEMS PROVIDED HEREUNDER. SELLER MAKES NO OTHER WARRANTY, GUARANTEE, OR REPRESENTATION OF ANY KIND WHATSOEVER. ALL OTHER WARRANTIES, INCLUDING BUT NOT LIMITED TO, MERCHANTABILITY AND FITNESS FOR PURPOSE, WHETHER EXPRESS, IMPLIED, OR ARISING BY OPERATION OF LAW, TRADE USAGE, OR COURSE OF DEALING ARE HEREBY DISCLAIMED.**

NOTWITHSTANDING THE FOREGOING, THERE ARE NO WARRANTIES WHATSOEVER ON ITEMS BUILT OR ACQUIRED WHOLLY OR PARTIALLY, TO BUYER'S DESIGNS OR SPECIFICATIONS.

5. Limitation Of Remedy: SELLER'S LIABILITY ARISING FROM OR IN ANY WAY CONNECTED WITH THE ITEMS SOLD OR THIS CONTRACT SHALL BE LIMITED EXCLUSIVELY TO REPAIR OR REPLACEMENT OF THE ITEMS SOLD, AT SELLER'S SOLE OPTION. IN NO EVENT SHALL SELLER BE LIABLE FOR ANY INCIDENTAL, CONSEQUENTIAL OR SPECIAL DAMAGES OF ANY KIND OR NATURE WHATSOEVER, INCLUDING BUT NOT LIMITED TO LOST PROFITS ARISING FROM OR IN ANY WAY CONNECTED WITH THIS AGREEMENT OR ITEMS SOLD HEREUNDER, WHETHER ALLEGED TO ARISE FROM BREACH OF CONTRACT, EXPRESS OR IMPLIED WARRANTY, OR IN TORT, INCLUDING WITHOUT LIMITATION, NEGLIGENCE, FAILURE TO WARN OR STRICT LIABILITY.

6. Changes, Reschedules and Cancellations: Buyer may request to modify the designs or specifications for the items sold hereunder as well as the quantities and delivery dates thereof, or may request to cancel all or part of this order, however, no such requested modification or cancellation shall become part of the contract between Buyer and Seller unless accepted by Seller in a written amendment to this Agreement. Acceptance of any such requested modification or cancellation shall be at Seller's discretion, and shall be upon such terms and conditions as Seller may require.

7. Special Tooling: A tooling charge may be imposed for any special tooling, including without limitation, dies, fixtures, molds and patterns, acquired to manufacture items sold pursuant to this contract. Such special tooling shall be and remain Seller's property notwithstanding payment of any charges by Buyer. In no event will Buyer acquire any interest in apparatus belonging to Seller which is utilized in the manufacture of the items sold hereunder, even if such apparatus has been specially converted or adapted for such manufacture and not withstanding any charges paid by Buyer. Unless otherwise agreed, Seller shall have the right to alter, discard or otherwise dispose of any special tooling or other property in its sole discretion at any time.

8. Buyer's Property: Any designs, tools, patterns, materials, drawings, confidential information or equipment furnished by Buyer or any other items which become Buyer's property, may be considered obsolete and may be destroyed by Seller after two (2) consecutive years have elapsed without Buyer placing an order for the items which are manufactured using such property, Seller shall not be responsible for any loss or damage to such property while it is in Seller's possession or control.

9. Taxes: Unless otherwise indicated on the face hereof, all prices and charges are exclusive of excise, sales, use, property, occupational or like taxes which may be imposed by any taxing authority upon the manufacture, sale or delivery of the items sold hereunder. If any such taxes must be paid by Seller or if Seller is liable for the collection of such tax, the amount thereof shall be in addition to the amounts for the items sold. Buyer agrees to pay all such taxes or to reimburse Seller therefore upon receipt of its invoice. If Buyer claims exemption from any sales, use or other tax imposed by any taxing authority, Buyer shall save Seller harmless from and against any such tax, together with any interest or penalties thereon which may be assessed if the items are held to be taxable.

10. Indemnity For Infringement of Intellectual Property Rights: Seller shall have no liability for infringement of any patents, trademarks, copyrights, trade dress, trade secrets or similar rights except as provided in this Part 10. Seller will defend and indemnify Buyer against allegations of infringement of U.S. Patents, U.S. Trademarks, copyrights, trade dress and trade secrets (hereinafter 'Intellectual Property Rights'). Seller will defend at its expense and will pay the cost of any settlement or damages awarded in an action brought against Buyer based on an allegation that an item sold pursuant to this contract infringes the Intellectual Property Rights of a third party. Seller's obligation to defend and indemnify Buyer is contingent on Buyer notifying Seller within ten (10) days after Buyer becomes aware of such allegations of infringement, and Seller having sole control over the defense of any allegations or actions including all negotiations for settlement or compromise. If an item sold hereunder is subject to a claim that it infringes the Intellectual Property Rights of a third party, Seller may, at its sole expense and option, procure for Buyer the right to continue using said item, replace or modify said item so as to make it noninfringing, or offer to accept return of said item and return the purchase price less a reasonable allowance for depreciation. Notwithstanding the foregoing, Seller shall have no liability for claims of infringement based on information provided by Buyer, or directed to items delivered hereunder for which the designs are specified in whole or part by Buyer, or infringements resulting from the modification, combination or use in a system of any item sold hereunder. The foregoing provisions of this Part 10 shall constitute Seller's sole and exclusive liability and Buyer's sole and exclusive remedy for infringement of Intellectual Property Rights.

If a claim is based on information provided by Buyer or if the design for an item delivered hereunder is specified in whole or in part by Buyer, Buyer shall defend and indemnify Seller for all costs, expenses or judgments resulting from any claim that such item infringes any patent, trademark, copyright, trade dress, trade secret or any similar right.

11. Force Majeure: Seller does not assume the risk of and shall not be liable for delay or failure to perform any of Seller's obligations by reason of circumstances beyond the reasonable control of Seller (hereinafter 'Events of Force Majeure'). Events of Force Majeure shall include without limitation, accidents, acts of God, strikes or labor disputes, acts, laws, rules or regulations of any government or government agency, fires, floods, delays or failures in delivery of carriers or suppliers, shortages of materials and any other cause beyond Seller's control.

12. Entire Agreement/Governing Law: The terms and conditions set forth herein, together with any amendments, modifications and any different terms or conditions expressly accepted by Seller in writing, shall constitute the entire Agreement concerning the items sold, and there are no oral or other representations or agreements which pertain thereto. This Agreement shall be governed in all respects by the law of the State of Ohio. No actions arising out of the sale of the items sold hereunder or this Agreement may be brought by either party more than two (2) years after the cause of action accrues.

11/98-P



Parker Hannifin Corporation
6035 Parkland Blvd.
Cleveland, Ohio 44124-4141
Telephone: (216) 896-3000
Fax: (216) 896-4000
www.parker.com

Parker Hannifin Corporation

About Parker Hannifin Corporation

Parker Hannifin is a leading global motion-control company dedicated to delivering premier customer service. A Fortune 500 corporation listed on the New York Stock Exchange (PH), our components and systems comprise over 1,400 product lines that control motion in some 1,000 industrial and aerospace markets. Parker is the only manufacturer to offer its customers a choice of hydraulic, pneumatic, and electromechanical motion-control solutions. Our company has the largest distribution network in its field, with over 7,500 distributors serving nearly 400,000 customers worldwide.

Parker's Charter

To be a leading worldwide manufacturer of components and systems for the builders and users of durable goods. More specifically, we will design, market and manufacture products controlling motion, flow and pressure. We will achieve profitable growth through premier customer service.

Product Information

North American customers seeking product information, the location of a nearby distributor, or repair services will receive prompt attention by calling the Parker Product Information Center at our toll-free number: 1-800-C-PARKER (1-800-272-7537). In Europe, call 00800-C-PARKER-H (00800-2727-5374).

The Aerospace Group is a leader in the development, design, manufacture and servicing of control systems and components for aerospace and related high-technology markets, while achieving growth through premier customer service.



The Climate & Industrial Controls Group designs, manufactures and markets system-control and fluid-handling components and systems to refrigeration, air-conditioning and industrial customers worldwide.

The Fluid Connectors Group designs, manufactures and markets rigid and flexible connectors, and associated products used in pneumatic and fluid systems.



The Seal Group designs, manufactures and distributes industrial and commercial sealing devices and related products by providing superior quality and total customer satisfaction.

The Hydraulics Group designs, produces and markets a full spectrum of hydraulic components and systems to builders and users of industrial and mobile machinery and equipment.



The Filtration Group designs, manufactures and markets quality filtration and clarification products, providing customers with the best value, quality, technical support, and global availability.

The Automation Group is a leading supplier of pneumatic and electromechanical components and systems to automation customers worldwide.



The Instrumentation Group is a global leader in the design, manufacture and distribution of high-quality critical flow components for worldwide process instrumentation, ultra-high-purity, medical and analytical applications.



Parker Hannifin Corporation

Instrumentation Connectors Division

P.O. Box 400004-1504

Huntsville, AL 35815-1504

USA

Phone: (256) 881-2040

Fax: (256) 881-5730

www.parker.com/ICD

Parker Hannifin plc

Instrumentation Products Division

Riverside Road

Pottington Industrial Estate

Barnstaple, Devon EX31 1NP

England

Phone: (44) (1271) 313131

Fax: (44) (1271) 373636

www.parker.com/instrumentation