

## Type 1082 Test Gauge



TYPE 1082

### FEATURES

- Externally adjustable dial (standard case)
- White aluminum dial, black numbers with polished mirror band
- Temperature-compensated movement significantly reduces temperature error
- MicroSpan™ adjustment for ease in span calibration
- Hydraulically staked movement with Teflon-coated gears and bearings improves stability

The standard Ashcroft® test gauge case style features a solid-front aluminum case with a hinged ring. The dial has a polished mirror band for pointer reflection to prevent parallax error and is available in 4½", 6" and 8½" dial sizes in both lower and back connection. Pointer is a balanced-friction adjustable design with red knife edge tip for easy reading. Optional aluminum or phenol cases are also available.

### Temperature Compensated Movement

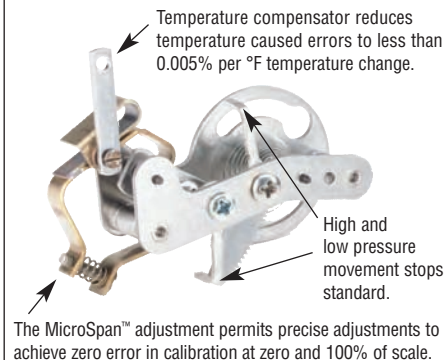

### Externally Adjustable Dial

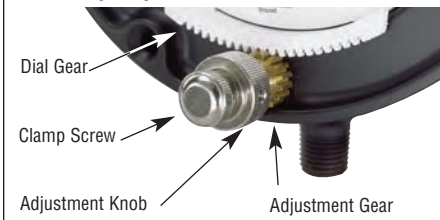

### SPECIFICATIONS

<b>Model Number:</b>	1082
<b>Accuracy:</b>	0.25/ASME B40.100, Grade 3A
<b>Ranges:</b>	Vac., compound, 10,000 psi
<b>Dial Size:</b>	4½", 6", 8½"
<b>Case Material:</b>	Aluminum, solid front, black epoxy coated
<b>Ring:</b>	Hinged steel, black wrinkle finish
<b>Tube and Socket Material:</b>	– (A) Phosphor bronze tube, brass socket – (P) Monel tube and socket
<b>Movement:</b>	400 Series SS rotary design, Teflon <sup>(1)</sup> S coated bearings, Micrometer span adjustment, Bimetallic temp. compensator (.005%/per °F max. temp. error)
<b>Connection Location:</b>	Lower or back for flush mounting <sup>(2)</sup>
<b>Connection Size:</b>	¼ or ½ NPT
<b>Window Material:</b>	Glass
<b>Pointer:</b>	Black-painted aluminum with red-painted, knife-edge tip
<b>Dial:</b>	Externally adjustable aluminum, black numerals with polished mirror band
<b>Weather Proof:</b>	No

### OPTIONS

Acrylic window: **XPD**  
 Safety glass window: **XSG**  
 Throttling devices: **XTS**  
 Carrying handle: **XCH**  
 Carrying case: **2505**  
 Aluminum case, threaded ring: **XAY<sup>(3)</sup>**  
 Phenol case, threaded ring: **XTY<sup>(3)</sup>**

(1) Registered TM of DuPont Co.  
 (2) Cases supplied with studs for flush mounting.  
 (3) Not available with externally adjustable dial

### HOW TO ORDER:

From Table A, Dial Size: 4½" : 45 | 1082 | P\* | 02L | XXX | 0/2,000 psi

From Table A, Case Type Number: 1082 \_\_\_\_\_

From Table B, Bourdon tube and socket: \_\_\_\_\_

From Table B, Connection: ¼ NPT (02), ½ NPT (04), Lower (L), Back (B) \_\_\_\_\_

From Optional Features: \_\_\_\_\_

From Range Table: 2000 psi \_\_\_\_\_

(\*) "S" denotes solid front case design

## Type 1082 Test Gauge

### STANDARD RANGES

psi	Minor Graduations					
	4½"	6"	8½"			
<b>Pressure</b>						
0/15	0.05	0.05	0.02			
0/30	0.1	0.1	0.05			
0/60	0.2	0.2	0.1			
0/100	0.5	0.2	0.2			
0/150	0.5	0.5	0.2			
0/200	0.5	0.5	0.5			
0/300	1	1	0.5			
0/400	1	1	1			
0/600	2	2	1			
0/800	2	2	2			
0/1000	5	2	2			
0/1500	5	5	2			
0/2000	10	5	5			
0/3000	10	10	5			
0/5000	20	10	10			
0/10,000	50	20	20			
<b>Vacuum</b>						
30 in.Hg/0	0.1	0.1	0.05			
<b>Compound</b>						
Hg/psi	Vac.	Pres.	Vac.	Pres.	Vac.	Pres.
30/0/15	0.2	0.1	0.2	0.1	0.1	0.05
30/0/30	0.5	0.2	0.2	0.1	0.2	0.1
30/0/60	0.5	0.2	0.5	0.2	0.5	0.2
30/0/100	1	0.5	0.5	0.5	0.5	0.2
30/0/150	1	0.5	1	0.5	0.5	0.5
30/0/200	2	1	1	0.5	1	0.5
30/0/300	2	1	2	1	1	0.5
30/0/400	5	2	2	1	2	1

### STANDARD RANGES

kg/cm2 – bar	kPa
<b>Pressure</b>	
0/1	0/100
0/1.6	0/160
0/2.5	0/250
0/4	0/400
0/6	0/600
0/10	0/1000
0/16	0/1600
0/25	0/2500
0/40	0/4000
0/60	0/6000
0/100	0/10,000
0/160	0/16,000
0/250	0/25,000
0/400	0/40,000
0/600	0/60,000
0/10,000	
<b>Vacuum</b>	
-1/0	-100/0
<b>Compound</b>	
-1/1.5	-100/150
-1/3	-100/300
-1/5	-100/500
-1/9	-100/900

### DIMENSIONS

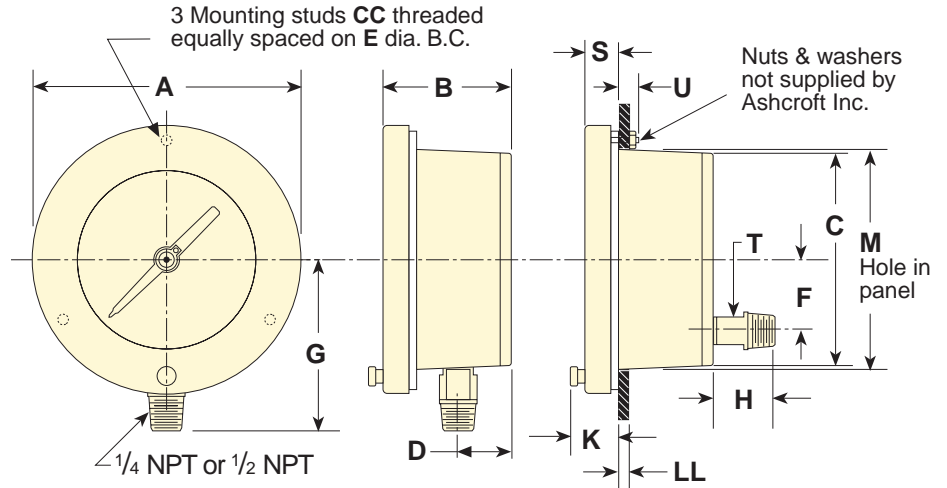

Model	Dial Size Inches	A	B	C	D	E	F	G	H	K	M	S	T	U	CC	LL
1082	4½"	6½ <sub>2</sub> (155)				5 <sub>8</sub> (137)		3 <sub>16</sub> (100)			4 <sub>8</sub> (124)				#10-24	
	6"	7 <sub>16</sub> (192)	2 <sub>8</sub> (73)	4 <sub>8</sub> (121)	1 <sub>16</sub> (30)	7 (178)	1 <sub>8</sub> (41)	4 <sub>2</sub> (114)	1 <sub>8</sub> (35)	1 <sub>16</sub> (34)	6 <sub>16</sub> (165)	5 <sub>16</sub> (16)	5 <sub>16</sub> (16)	3 <sub>8</sub> (19)	¼-20	5 <sub>16</sub> to 1 <sub>2</sub> (3) (13)
	8½"	10 <sub>16</sub> (257)				9 <sub>16</sub> (244)		6 (152)			9 (229)				¼-20	

\*Millimeters shown in ( ).

Table A - Case selection & mounting						
Dial Size (in)	Ordering Code	Case Type	Case: Material Finish	Ring: Style Material Finish	Mounting / Connection	
4½	(45)	1082	Aluminum,	Hinged	Stem –	Lower or back Lower <sup>(1)</sup> or back
6	(60)		Black, epoxy	Steel	Flush –	
8½	(85)		Coated	Wrinkle finish		

Table B - System Location and Connection Bourdon Tube & Tip Material		Socket Material	Tube & Socket Code	Case Style Code	NPT Conn. & Code	Conn. Location & Code	Range Selection Limits (psi)
(all joints TIG welded except code "A")							
Phosphor bronze tube, Brass tip, silver brazed		Brass	(A)-Tube	(S) Solid Front	(02) ½	Lower (L)	Vac./400
Monel 400		Monel 400	(P)	(S) Solid Front	(04) ½	Back (B)	Vac./10,000

NOTES: (1) Standard case only.

# Type 1082 Test Gauge – XAY, XTY Case Options

## XAY DIMENSIONS

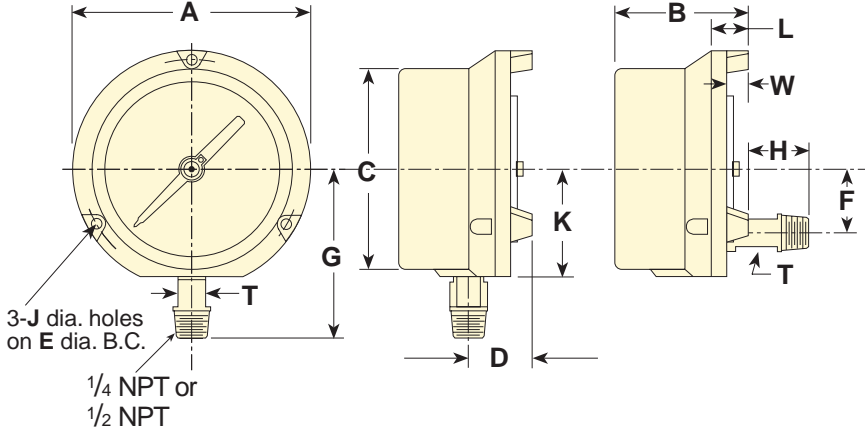

Model	Dial Size Inches	A	B	C	D	E	F	G	H	J	K	L	T	W
1082 XAY	4 1/2"	5 1/16 (143)	3 1/16 (87)	4 (124)	1 (41)	5 3/8 (137)	1 (41)	3 1/16 (94)	7/8 (20)	.218	2 (67)	1 1/16 (27)	5/8 (16)	
	6"	7 (194)	3 1/2 (89)	6 (162)	1 (41)	7 (178)	1 (41)	4 3/16 (113)	7/8 (20)	.218	2 (67)	1 1/16 (27)	5/8 (16)	

\*Millimeters shown in ( ).

## XTY DIMENSIONS

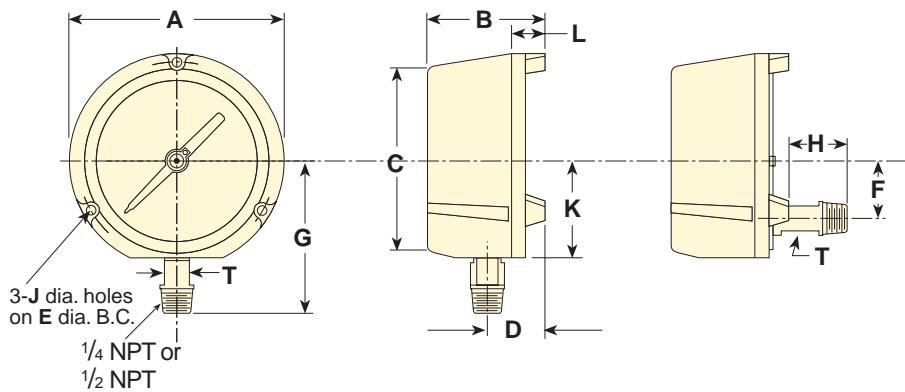

Model	Dial Size Inches	A	B	C	D	E	F	G	H	J	K	L	T
1082 XTY	4 1/2"	5 1/16 (143)	3 1/16 (87)	4 (124)	1 (41)	5 (137)	1 (41)	3 1/16 (94)	7/8 (20)	.218	2 (67)	1 1/16 (27)	5/8 (16)

\*Millimeters shown in ( ).