



INLINE SEAL™ Diaphragm Seals

Wafer Inline Diaphragm Seal

Type L981.10

Diaphragm Seals

Application

Process industry diaphragm seal to combine with Bourdon tube pressure gauges or transmitters. Intended for rapidly flowing corrosive, contaminated, hot or light to medium viscous pressure media.

Design

Body with cylindrical diaphragm to be sandwiched between two pipe flanges. Requires hydraulic fluid to transmit pressure to instrument.

Process Connection

1" to 4" per ASME B16.5; other see options

Suitable Pressure Ranges

From 10 PSI to class2500 (for lower ranges consult factory)

Available Options (connections, materials, etc.)

See Selection Guide (over)

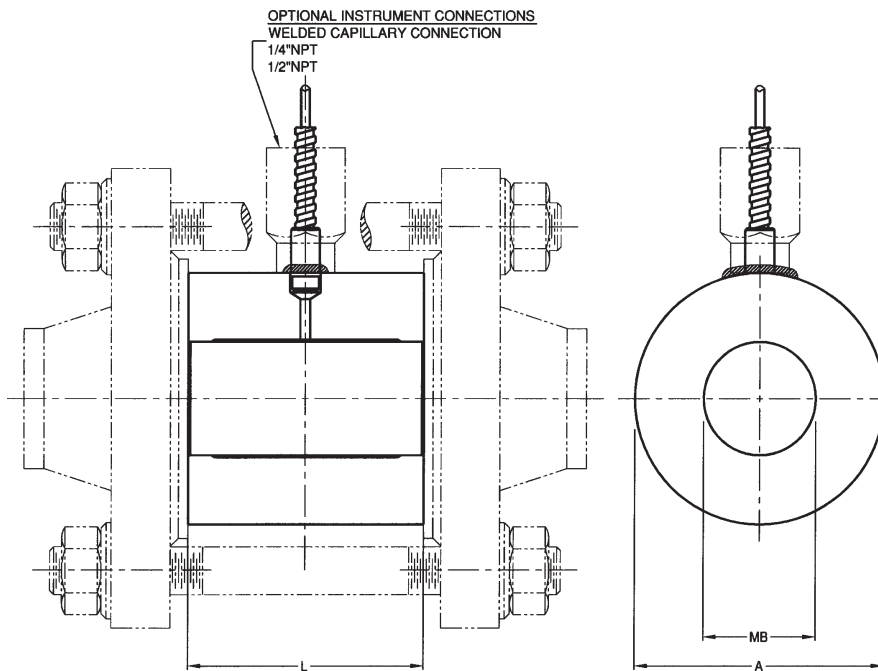
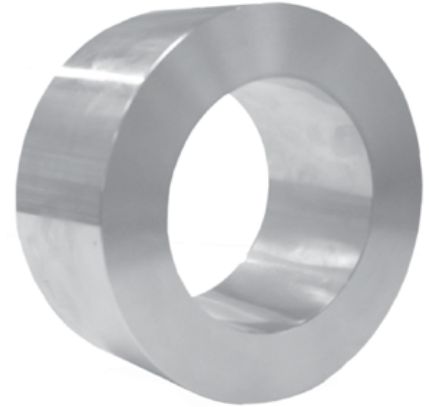

DM=EFFEKTIVE DIAPHRAGM DIAMETER
 CLASS=FLANGE RATING PER ASME B16.5
 ALL DIMENSIONS IN INCHES UNLESS OTHERWISE NOTED

SIZE	CLASS	A	MB	L	WEIGHT lbs
1"	150#-2500#	2.4	1.12	2.36	3.1
1.5"		3.3	1.69		4.8
2"		3.7	2.15		5.5
3"		5.1	3.25		8.8
4"		5.9	4.21		10.3
3"		7.3	5.20		15.0
4"		8.5	6.26		20.9

DWG.#2212072-5

To determine the effects of temperature and response time in a specific application, contact the factory for an **Application Questionnaire**. The information provided will allow WIKAI Technical Support to accurately model your application parameters using state-of-the-art computer simulation techniques.

ACS L981.10
(ACS 98.03)

Selection Guide - 981.10

981.10,1/4X1.0,SS,SS

Notes

1. Suitable pressure ranges 0-10 PSI to 0-2,500 PSI. Maximum working pressure based on mounting flange rating per AMSE B16.5.
2. Sealing face to fit piping per ASME B16.5 raised face smooth finish open flanges. Process connections to meet other sealing faces available, consult factory for availability.
3. Upper housing is a process wetted component.
4. For titanium diaphragm, upper housing material must be titanium also.

*Items in **bold** are available from stock (subject to prior sales). For optional items, consult factory for current lead-time.*

Diaphragm Material

SS = 316 stainless steel

MO = Monel® 400

HB = Hastelloy® B-2

HC = Hastelloy® C-276

PF = 316 stainless steel, PFA coating (500°F max.)

EC = 316 stainless steel, ECTFE (Halar®) coating (300°F max.)

TA = Tantalum

TI = Titanium, grade 2 (See note 4)

Upper Housing Material (See note 3)

SS = 316 stainless steel

MO = Monel® 400

HB = Hastelloy® B-2

HC = Hastelloy® C-276

TI = Titanium, grade 2

Process Connection (See note 2)

1.0 = 1" Pipe

1.5 = 1-1/2" Pipe

2.0 = 2" Pipe

3.0 = 3" Pipe

4.0 = 4" Pipe

6.0 = 6" Pipe

8.0 = 8" Pipe

Instrument Connection

1/4 = 1/4" NPT female

1/2 = 1/2" NPT female

CPL = Capillary connection (To weld capillary directly to seal)

Diaphragm Seal Design (See note 1)

981.10 = INLINE SEAL™

THE MEASURE OF
Total Performance™

Ordering Information:

State computer part number (if available) / type number / size / range / connection size and location / options required.

Specifications given in this price list represent the state of engineering at the time of printing. Modifications may take place and the specified materials may change without prior notice

03/07



WIKA Instrument Corporation

1000 Wiegand Boulevard

Lawrenceville, Georgia 30043-5868

Tel: 770-513-8200 Fax: 770-338-5118

<http://www.wika.com> e-mail: diaphragmseal@wika.com