



Pressure Gauge Accessories

Pressure Gauge Siphons

Type 910.15.100 Pigtail

Type 910.15.200 Coil

Accessories, Mechanical

Application

Pressure gauge siphons are used to protect the pressure gauge from the effect of hot pressure media such as steam and also to reduce the effect of rapid pressure surges. The pressure medium forms a condensate and is collected inside the coil or pigtail portion of the siphon. The condensate prevents the hot media from coming in direct contact with the pressure instrument. When the siphon is first installed, it should be filled with water or any other suitable separating liquid.

Forms

Pigtail siphon

Coil siphon

Standard Features

Pressure Connection

See table on reverse side

Materials

Brass

Steel A120, schedule 40

Steel A106B, schedule 80 & 160

316 stainless steel, schedules 80 & 160

Chrome Moly steel (A335 P22), XX Heavy

Optional Extras

Alternate threads

316 stainless steel cleaned for oxygen service

Media Temperature Reduction

Approximately 75° F for each 12" section of ½" pipe. Actual reduction dependent on process/application variables.



Coil- used primarily for horizontal installations



Pigtail- used primarily for vertical installations

Dimensions

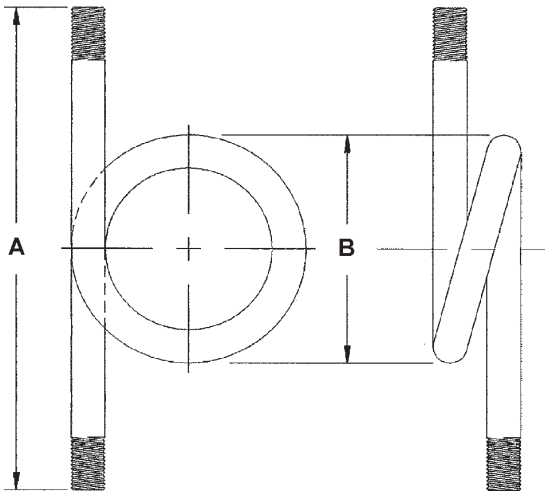

Type 910.15.100 Pigtail Siphon

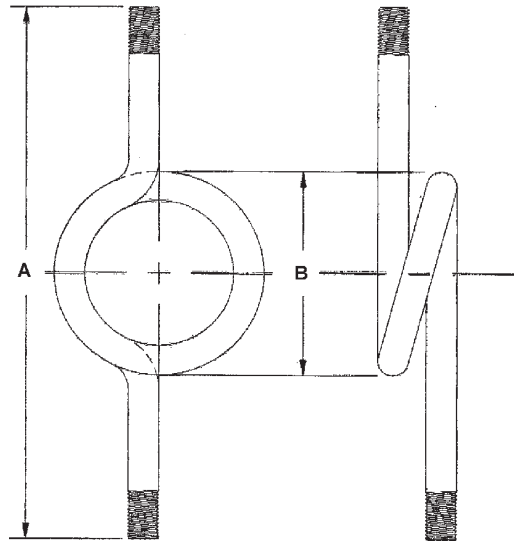

Type 910.15.200 Coil Siphon

Pigtail Siphons

Form	Body Material	Size	Press. Rating (PSI)	Temp. Rating (°F)	A (in.) ± 0.25	B (in.) ± 0.25	Part Number
d	Brass	1/4" NPT	250	400	5.5	2.5	4201779
	Steel, Sch 40	1/4" NPT	500	400	5.5	2.5	4201787
	316SS	1/4" NPT	500	400	5.5	2.5	4201761

Coil Siphons

Form	Body Material	Size	Press. Rating (PSI)	Temp. Rating (°F)	A (in.) ± 0.25	B (in.) ± 0.50	Part Number
e	Brass	1/4" NPT	250	400	7.25	2.63	4201809
	Steel, Sch 40	1/4" NPT	500	400	7.25	2.63	4201817
	Steel, Sch 80	1/4" NPT	3360	400	7.25	2.63	4201825
	Steel, Sch 80	1/2" NPT	3000	400	12.0	2.63	4201833
	Steel, Sch 160	1/2" NPT	3620	700	12.0	4.13	4201841
	316SS, Sch 80	1/2" NPT	2650	500	12.0	4.13	4201850
	316SS, Sch 160	1/2" NPT	5600	500	12.0	4.13	4201795
	Chr. Moly (XXH)	1/2" NPT	8205	750	12.0	4.13	4201868

THE MEASURE OF
Total Performance™

Ordering Information:

State computer part number (if available) / model number / size / range / connection size and location / options required.

Specifications given in this price list represent the state of engineering at the time of printing. Modifications may take place and the specified materials may change without prior notice



WIKAL Instrument Corporation

1000 Wiegand Boulevard

Lawrenceville, Georgia 30043-5868

Tel: 770-513-8200 Fax: 770-338-5118

<http://www.wika.com> e-mail: info@wika.com