

450 Series

Solid Front • Field Liquid Fillable • Turret Case

PROCESS GAUGES



450B shown

- ▶ 4 1/2" Dial Size
- ▶ ±0.5% Accuracy
- ▶ Solid Front/Blow-Out Back
- ▶ Field Liquid Fillable

The Trerice **450 Series** Process Gauge is designed for the petrochemical and industrial process industries. This solid front, blow-out back gauge is noted for its fiberglass reinforced polypropylene turret case and screwed ring; its sturdy interior design; and its field liquid-fill capability (no kit required). The 450 Series can withstand the most rugged industrial applications, while maintaining precise accuracy. Wetted parts are bronze tube/brass socket, stainless steel, or Monel.

- Optional features available: Please consult the Options & Accessories Section for details.
- For correct use and application of all pressure gauges, please refer to: Pressure Gauge Standard ASME B40.100.

Specifications

Models	Wetted Parts
450B (dry) 450LFB (liquid-filled)	Brass tube, brass socket
450SS (dry) 450LFSS (liquid-filled)	316 stainless steel* tube and socket
450M (dry) 450LFM (liquid-filled)	Monel tube and socket (meets NACE MR 01.75)

Dial Size	4 1/2"
Fill	Glycerine. Other fills available. See Options & Accessories
Movement	Stainless steel
Connection	Lower male or lower back male, 1/4 or 1/2 NPT
Case	Fiberglass reinforced polypropylene, turret, solid front with blow-out back
Ring	Threaded fiberglass reinforced polypropylene
Window	Acrylic
Pointer	Micro adjustable, black finished
Dial Face	Aluminum, white background with black graduations and markings
Accuracy	±0.5% Full Scale, ASME B40.100 Grade 2A

Maximum Temperature	
450B, 450SS, 450M:	250°F (121°C)
450LFB, 450LFSS, 450LFM:	150°F (65°C)

Approximate Shipping Weight	
450B, 450SS, 450M:	2.2 lbs [1.00 kg]
450LFB, 450LFSS, 450LFM:	3.1 lbs [1.41 kg]

* Ranges over 10,000 PSI have Ni-Span-C tube.

HOW TO ORDER

Sample Order Number: **450LFB 45 02 L D 110**

Model	Dial Size	Connection Size	Connection Location	Units of Measure	Range Code
450B 450LFB 450SS 450LFSS 450M 450LFM	45 4 1/2"	02 1/4 NPT 04 1/2 NPT	L Lower B Back	A psi B kPa C kg/cm ² D psi/kPa E psi & kg/cm ²	See Standard Ranges

450 Series

All dimensions are nominal. Dimensions in [] are in millimeters.

Solid Front • Field Liquid Fillable • Turret Case

PROCESS GAUGES

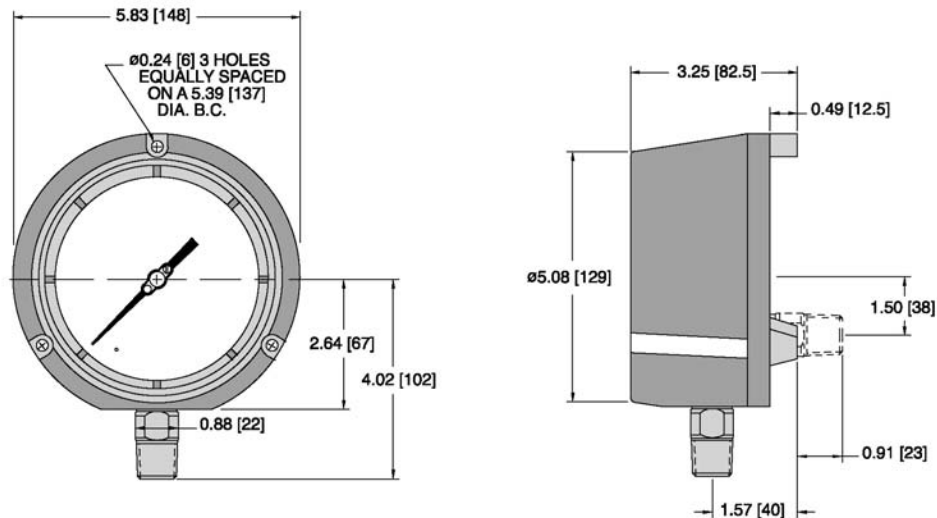

Standard Ranges

psi Ranges (A)				kPa Ranges (B)				kg/cm ² Ranges (C)			
Range Code	Specific Range (psi)	Figure Intervals	Minor Divisions	Range Code	Specific Range	Figure Intervals	Minor Divisions	Range Code	Specific Range	Figure Intervals	Minor Divisions
010	30" Hg to 0	5	0.2	010	-100 to 0 kPa	10	1	010	76 cm Hg to 0	10	0.5
020	30" Hg to 15 psi	5/5	0.5/0.2	020	-100 to 100 kPa	20	2	020	76 cm Hg to 1 kg/cm ²	20/0.2	1/0.02
030	30" Hg to 30 psi	10/5	1/0.5	030	-100 to 200 kPa	50	2	030	76 cm Hg to 2 kg/cm ²	20/0.5	2/0.02
040	30" Hg to 60 psi	10/10	1/1	040	-100 to 400 kPa	50	5	040	76 cm Hg to 4 kg/cm ²	25/0.5	5/0.05
050	30" Hg to 100 psi	30/10	2/1	050	-100 to 600 kPa	100	5	050	76 cm Hg to 7 kg/cm ²	76/1	5/0.1
060	30" Hg to 150 psi	30/20	5/2	060	-100 to 1000 kPa	100	10	060	76 cm Hg to 10 kg/cm ²	76/1	15/0.1
070	30" Hg to 300 psi	30/50	5/2	070	-100 to 2000 kPa	200	20	070	76 cm Hg to 21 kg/cm ²	76/2	19/0.2
080	0 to 15 psi	3	0.1	080	0 to 100 kPa	10	1	080	0 to 1 kg/cm ²	0.1	0.01
090	0 to 30 psi	5	0.2	090	0 to 200 kPa	20	2	090	0 to 2 kg/cm ²	0.2	0.02
100	0 to 60 psi	10	0.5	100	0 to 400 kPa	50	5	100	0 to 4.2 kg/cm ²	0.5	0.05
110	0 to 100 psi	10	1	110	0 to 700 kPa	100	5	110	0 to 7 kg/cm ²	1	0.05
120	0 to 160 psi	20	1	120	0 to 1200 kPa	200	10	120	0 to 11 kg/cm ²	1	0.1
130	0 to 200 psi	20	2	130	0 to 1500 kPa	300	10	130	0 to 14 kg/cm ²	2	0.1
140	0 to 300 psi	50	2	140	0 to 2000 kPa	200	20	140	0 to 21 kg/cm ²	3	0.2
150	0 to 400 psi	50	5	150	0 to 3000 kPa	300	20	150	0 to 28 kg/cm ²	4	0.2
160	0 to 600 psi	50	5	160	0 to 4000 kPa	500	50	160	0 to 42 kg/cm ²	6	0.5
180	0 to 1000 psi	100	10	180	0 to 7000 kPa	1000	50	180	0 to 70 kg/cm ²	10	0.5
Ranges over 1000 psi are not available on 450B and 450LFB.											
190	0 to 1500 psi	300	10	190	0 to 10,000 kPa	1000	100	190	0 to 100 kg/cm ²	10	1
200	0 to 2000 psi	200	20	200	0 to 14,000 kPa	2000	100	200	0 to 140 kg/cm ²	20	1
210	0 to 3000 psi	300	20	210	0 to 20,000 kPa	2000	200	210	0 to 210 kg/cm ²	30	2
220	0 to 5000 psi	500	50	220	0 to 35,000 kPa	5000	250	220	0 to 350 kg/cm ²	50	2
230	0 to 10,000 psi	1000	100	230	0 to 60,000 kPa	10,000	500	230	0 to 700 kg/cm ²	100	10
Ranges over 10,000 psi are only available on 450SS and 450LFSS, and have Ni-Span-C tubes.											
240	0 to 15,000 psi	2000	100	240	0 to 100,000 kPa	20,000	1000	240	0 to 1000 kg/cm ²	100	10
250	0 to 20,000 psi	2000	200	250	0 to 140,000 kPa	20,000	1000	250	0 to 1400 kg/cm ²	200	20

For dual scale ranges, specify the appropriate Units of Measure: **D** (psi/kPa) or **E** (psi & kg/cm²) followed by the equivalent **A** (psi) Range Code. Other pressure ranges are also available including: Altitude, Ammonia, Refrigerant and Receiver. Consult Special Application Ranges section or factory for availability.