

General Service Gauges

Series "U"



- Dial Size: 1-1/2", 2", 2-1/2", 3-1/2", 4", 4-1/2", 6"
- Superb Quality, Economical Price
- ISO 9002 - Certified Facility

General Service Steel Case Gauges

are an economical and general purpose gauge for pressure measurements from vacuum/compound through 10,000 psi. Typical applications include pumps, compression, pool filters, commercial and industrial equipment.

SERIES "U" STEEL CASE DIMENSIONS

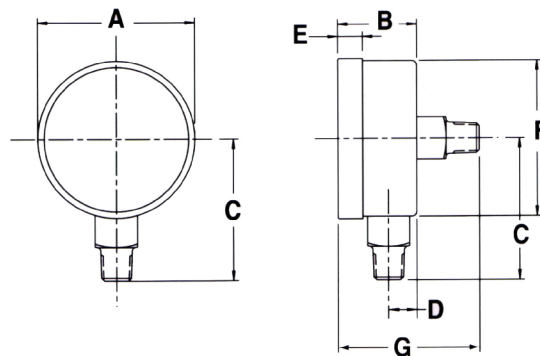

GAUGE DIMENSIONS

Gauge Size/Type		A	B	C	D	E	F	
Lower Connection	1.5"	Inch	1.66	0.99	1.45	0.33	0.32	1.61
		mm	42	25	37	8	5	41
	2"	Inch	2.08	1.13	1.8	0.37	0.39	2.01
		mm	53	28	46	9	10	51
	2.5"	Inch	2.48	1.13	1.95	0.42	0.39	2.43
		mm	63	29	50	11	10	62
	3.5"	Inch	3.47	1.16	2.68	0.46	0.43	3.42
		mm	88	29	68	12	11	87
	4"	Inch	3.94	1.41	3.01	0.46	0.55	3.87
		mm	100	36	77	12	14	99
	4.5"	Inch	4.45	1.34	3.29	0.49	0.49	4.37
		mm	113	34	84	12	12	111
	6"	Inch	5.95	1.83	4.38	0.68	0.93	5.84
		mm	152	47	112	17	24	149
Gauge Size/Type		A	B	E	F	G		
Back Connection	1.5"	Inch	1.66	0.99	0.31	1.61	1.56	
		mm	42	25	8	41	40	
	2"	Inch	2.08	1.13	0.39	2.01	1.85	
		mm	53	29	10	51	47	
	2.5"	Inch	2.49	1.13	0.39	2.44	1.87	
		mm	63	29	10	62	47	
	3.5"	Inch	3.47	1.16	0.43	3.42	1.90	
		mm	88	29	11	87	48	

Cheng and Associates, INC.

20522 Carrey Road · Walnut · CA · 91789 · Phone: 909-839-0506 · Fax: 909-839-0516