

Dimensions

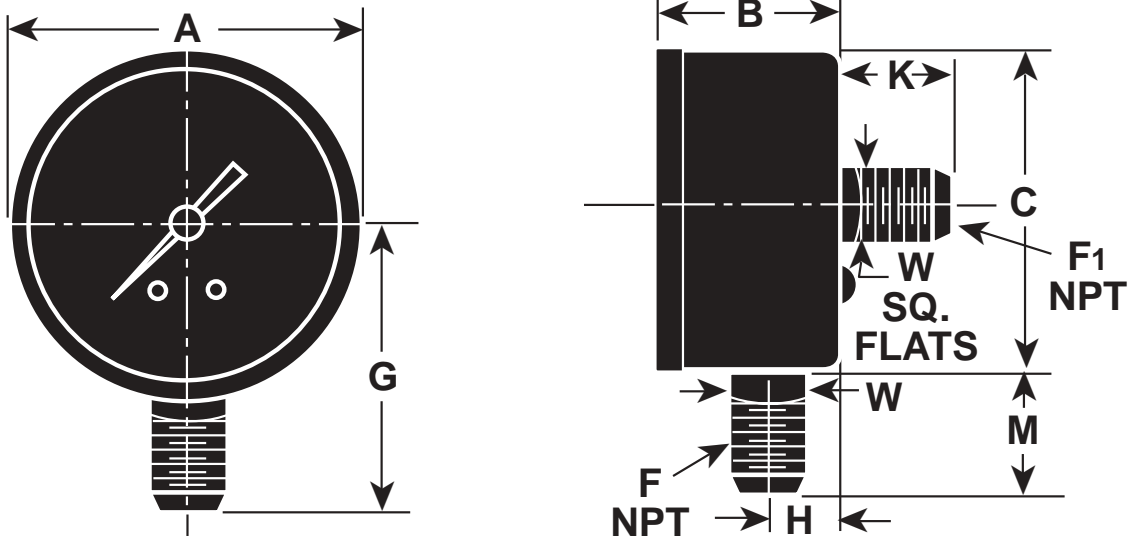

TYPE 1005

DIAL SIZE inches (mm)	A	B		C	F NPT	F1 NPT	G	H	K	M	W		WEIGHT (ozs)
		LOWER	BACK								LOWER	BACK	
1½"	1.62 (42)	0.86 (22)	0.99 (25)	1.60 (41)	⅛ or ¼	⅛	1.46 (37)	0.28 (7)	0.67 (17)	0.66 (17)	0.56 (14)	0.44 (11)	2
2"	2.09 (53)	1.04 (26)	1.04 (26)	2.05 (52)	⅛ or ¼	⅛ or ¼	1.85 (47)	0.34 (9)	0.88 (22)	0.82 (21)	0.56 (14)	0.56 (14)	3.6
2½"	2.73 (69)	1.10 (28)	1.10 (28)	2.68 (68)	⅛ or ¼	⅛ or ¼	2.18 (55)	0.36 (9)	0.88 (22)	0.84 (21)	0.56 (14)	0.56 (14)	4.5
3½"	3.67 (93)	1.21 (31)	1.21 (31)	3.61 (92)	⅛ or ¼	⅛ or ¼	2.72 (69)	0.43 (11)	0.88 (22)	0.92 (23)	0.56 (14)	0.56 (14)	6.8